



**Waukesha
Cherry-Burrell**

® An SPX Process Equipment Operation

Operation and Maintenance Manual 200 Series Centrifugal Pumps



**Read and understand this manual
prior to installing, operating or servicing this equipment.**



611 Sugar Creek Road
Delavan, WI 53115 USA

Tel: (800) 252-5200 or (262) 728-1900
Fax: (800) 252-5012 or (262) 728-4904

E-mail: info@processequipment.spx.com
Web site: www.spxprocessequipment.com

Information contained in this manual is subject to change without notice and does not represent a commitment on the part of Waukesha Cherry-Burrell. No part of this manual may be reproduced or transmitted in any form or by any means, electronic or mechanical, including photocopying and recording, for any purpose, without the express written permission of Waukesha Cherry-Burrell.

Copyright © 2005 All Rights Reserved.

Gore-Tex is a registered trademark of W.L. Gore & Associates, Inc.
Kalrez is a registered trademark of DuPont Dow Elastomers.
Chemraz is a registered trademark of Greene, Tweed & Co.

Issued Date: **December 2001**
Revision Date: **April 2005**
Publication: **95-03009**

Table of Contents

Waukesha Cherry-Burrell Warranty	5
Shipping Damage or Loss	5
Warranty Claim	5
Safety	6
Care of Stainless Steel	7
Stainless Steel Corrosion	7
Elastomer Seal Replacement Following Passivation	7
Introduction	8
Manual Content	8
Factory Inspection	8
Receiving Your Pump	8
Receiving and Inspection	8
Pump Characteristics	8
200 Series Base Mount Description	9
Base Mount Components	9
Motor Adapter	9
Stand	9
Base (Optional)	9
Performance Characteristics	13
Quality Control	13
Authorization	13
Standard Construction	13
Construction Options	13
Operating Parameters	13
Capacities	14
Dimensions	15
Centrifugal 200 Series Pump and Pedestal Weights	21
Installation	23
Pump Location	23
Pump Leveling	23
Supply and Discharge Piping/Valves	23
Installations That May Cause Operation Problems	24
Electrical Connections	25
Flush Seal Option	25
Type 4 Seal	25
Before First Startup	26
Clean Pump and Piping	26
Cleaning Safety Procedures	26
Manual Cleaning	26
Cleaning-In-Place (CIP)	26
Preliminary Test Run	26
Check For Possible Motor Overload Conditions	26
Operation	27
Starting the Pump	27
Priming the Pump	27
Priming the Pump With the Feed Source Above Pump Level	27
Priming the Pump With the Feed Source Below Pump Level	27
Stopping the Pump	28
Maintenance	29
Scheduled Maintenance	29
Routine Maintenance	29
Disassembly of Pump With a Type 1 Seal	29
Removal of the Water Cascade	29
Inspect Parts	31
Assembly of Pump With a Type 1 Seal	31

Table of Contents

Backplate Assembly	31
Backplate/Impeller Assembly	31
Type 4 Double Seal	34
Disassembly Type 4 Seal	34
Removal of the Water Cascade	34
Assembly of Type 4 Seal	36
Standard Seal Dimensions	39
Disassembly of Modular Base Mounted Pumps	40
Disassembling The Outer Seal Assemblies	40
Assembling the Outer Seal Assemblies	41
Pre-assembled (Cartridge) Seals	41
Disassembly of Pre-assembled (Cartridge) Seals	41
Assembly of a Pump With Pre-assembled (Cartridge) Seals	42
Pedestal Base Mounted Pump Housing Lubrication	44
Lubrication Schedule	45
Pump Alignment	45
Checking Angular Alignment	45
Checking Parallel Alignment	45
Cartridge Seal Dimensions	46
Servicing the Electric Motor	47
General Service Information	47
Motor Lubrication Instructions	47
Parts Lists	48
Seal Kits	48
Basic Seal Kit - Type 1 Seal - Sanitary Pump Model	48
Complete Seal Kit - Type 1 Seal - Sanitary Pump Model	48
Basic Seal Kit - Type 4 Seal - Sanitary Pump Model	48
Complete Seal Kit - Type 4 Seal - Sanitary Pump Model	49
Motor Shaft Shims	49
Seal Components All Pumps	50
2045 Components (Close Coupled)	52
2065 Components (Close Coupled)	54
2065LV Components (Close Coupled)	56
2065HV Components (Close Coupled)	58
2075 Components (Close Coupled)	60
2085 Components (Close Coupled)	62
2085LV Components (Close Coupled)	64
2105 Components (Close Coupled)	66
Motor Mounts	68
Pedestal Mounted Pumps Small Bore	69
Metric System Parts	75
Troubleshooting	76

Waukesha Cherry-Burrell Warranty

Seller warrants its products to be free from defect in materials and workmanship for a period of one (1) year from the date of shipment. This warranty shall not apply to products which require repair or replacement due to normal wear and tear or to products which are subjected to accident, misuse or improper maintenance. This warranty extends only to the original Buyer. Products manufactured by others but furnished by Seller are exempted from this warranty and are limited to the original manufacturer's warranty.

Seller's sole obligation under this warranty shall be to repair or replace any products that Seller determines, in its discretion, to be defective. Seller reserves the right either to inspect the products in the field or to request their prepaid return to Seller. Seller shall not be responsible for any transportation charges, duty, taxes, freight, labor or other costs. The cost of removing and/or installing products which have been repaired or replaced shall be at Buyer's expense.

Seller expressly disclaims all other warranties, express or implied, including without limitation any warranty of merchantability of fitness for a particular purpose. The foregoing sets forth Seller's entire and exclusive liability, and Buyer's exclusive and sole remedy, for any claim of damages in connection with the sale of products. In no event shall Seller be liable for any special consequential incidental or indirect damages (including without limitation attorney's fees and expenses), nor shall Seller be liable for any loss of profit or material arising out of or relating to the sale or operation of the products based on contract, tort (including negligence), strict liability or otherwise.

Shipping Damage or Loss

If equipment is damaged or lost in transit, file a claim at once with the delivering carrier. The carrier has signed the Bill of Lading acknowledging that the shipment has been received from WCB in good condition. WCB is not responsible for the collection of claims or replacement of materials due to transit shortages or damages.

Warranty Claim

Warranty claims must have a **Returned Goods Authorization (RGA)** from the Seller before returns will be accepted.

Claims for shortages or other errors, exclusive of transit shortages or damages, must be made in writing to Seller within ten (10) days after delivery. Failure to give such notice shall constitute acceptance and waiver of all such claims by Buyer.

Safety**READ AND UNDERSTAND THIS MANUAL
PRIOR TO INSTALLING, OPERATING OR SERVICING THIS EQUIPMENT**

Waukesha Cherry-Burrell recommends users of our equipment and designs follow the latest Industrial Safety Standards. At a minimum, these should include the industrial safety requirements established by:

1. Occupational Safety and Health Administration (OSHA), Title 29 of the CFR
Section 1910.212- General Requirements for all Machines
2. National Fire Protection Association, ANSI/NFPA 79
ANSI/NFPA 79- Electrical Standards for Industrial Machinery
3. National Electrical Code, ANSI/NFPA 70
ANSI/NFPA 70- National Electrical Code
ANSI/NFPA 70E- Electrical Safety Requirement for Employee Workplaces
4. American National Standards Institute, Section B11

Attention: Servicing energized industrial equipment can be hazardous. Severe injury or death can result from electrical shock, burn, or unintended actuation of controlled equipment. Recommended practice is to disconnect and lockout industrial equipment from power sources, and release stored energy, if present. Refer to the National Fire Protection Association Standard No. NFPA70E, Part II and (as applicable) OSHA rules for Control of Hazardous Energy Sources (Lockout-Tagout) and OSHA Electrical Safety Related Work Practices, including procedural requirements for:

- Lockout-tagout
- Personnel qualifications and training requirements
- When it is not feasible to de-energize and lockout-tagout electrical circuits and equipment before working on or near exposed circuit parts

Locking and Interlocking Devices: These devices should be checked for proper working condition and capability of performing their intended functions. Make replacements only with the original manufacturer's renewal parts or kits. Adjust or repair in accordance with the manufacturer's instructions.

Periodic Inspection: Industrial equipment should be inspected periodically. Inspection intervals should be based on environmental and operating conditions and adjusted as indicated by experience. At a minimum, an initial inspection within 3 to 4 months after installation is recommended. Inspection of the electrical control systems should meet the recommendations as specified in the National Electrical Manufacturers Association (NEMA) Standard No. ICS 1.3, Preventative Maintenance of Industrial Control and Systems Equipment, for the general guidelines for setting-up a periodic maintenance program.

Replacement Equipment: Use only replacement parts and devices recommended by the manufacturer to maintain the integrity of the equipment. Make sure the parts are properly matched to the equipment series, model, serial number, and revision level of the equipment.

Warnings and cautions are provided in this manual to help avoid serious injury and/or possible damage to equipment:



DANGER: marked with a stop sign.

Immediate hazards which WILL result in severe personal injury or death.



WARNING: marked with a warning triangle.

Hazards or unsafe practices which COULD result in severe personal injury or death.



CAUTION: marked with a warning triangle.

Hazards or unsafe practices which COULD result in minor personal injury or product or property damage.

Care of Stainless Steel

Stainless Steel Corrosion

Corrosion resistance is greatest when a layer of oxide film is formed on the surface of stainless steel. If film is disturbed or destroyed, stainless steel becomes much less resistant to corrosion and may rust, pit or crack.

Corrosion pitting, rusting and stress cracks may occur due to chemical attack. Use only cleaning chemicals specified by a reputable chemical manufacturer for use with 300 series stainless steel. Do not use excessive concentrations, temperatures or exposure times. Avoid contact with highly corrosive acids such as hydrofluoric, hydrochloric or sulfuric. Also avoid prolonged contact with chloride-containing chemicals, especially in presence of acid. If chlorine-based sanitizers are used, such as sodium hypochlorite (bleach), do not exceed concentrations of 150 ppm available chlorine, do not exceed contact time of 20 minutes, and do not exceed temperatures of 104°F (40°C).

Corrosion discoloration, deposits or pitting may occur under product deposits or under gaskets. Keep surfaces clean, including those under gaskets or in grooves or tight corners. Clean immediately after use. Do not allow equipment to set idle, exposed to air with accumulated foreign material on the surface.

Corrosion pitting may occur when stray electrical currents come in contact with moist stainless steel. Ensure all electrical devices connected to the equipment are correctly grounded.

Elastomer Seal Replacement Following Passivation

Passivation chemicals can damage product contact areas of WCB equipment. Elastomers (rubber components) are most likely to be affected. Always inspect all elastomer seals after passivation is completed. Replace any seals showing signs of chemical attack. Indications may include swelling, cracks, loss of elasticity or any other noticeable changes when compared with new components.

Introduction

Manual Content

Maintenance procedures in this manual do not cover aseptic or high pressure pump applications. These are covered in special addendums available from your Waukesha Cherry-Burrell representative.

***NOTE:** In addition to covering standard pump impeller shaft diameter and basic information, this manual also addresses metric impeller shaft diameter and basic information on total metric pump system requirements. See "Metric System Parts" on page 94.*

Factory Inspection

Each Waukesha pump is shipped completely assembled, lubricated and ready for use. (Make sure you review "Operation" on page 27 before operating your pump).

Receiving Your Pump

All ports are covered at the factory to keep out foreign objects during transit. If the covers are missing or damaged, a thorough inspection of fluid head, by removing the pump cover, is recommended. Be sure pumping head is clean and free of foreign material before rotating shaft.

Receiving and Inspection

1. WCB equipment is run tested or inspected prior to shipment. When leaving the factory, it is well crated for normal transportation procedures. WCB cannot, however, guarantee safe arrival. Therefore, upon receipt of this equipment, check the received items against the packing list for damaged or missing parts. Check the packing material thoroughly for small parts.
2. Visually inspect for damage or loss. Damage or loss should be reported immediately to the delivery carrier while present. Following the immediate notification of the lost or damaged parts, a detailed description of the loss or damage, and a cash value should be claimed against the carrier. WCB's responsibility terminates F.O.B. point of manufacture unless otherwise specified per the General Terms and Conditions of Sale as published by WCB and amended from time to time. Contact WCB Order Services if shipping information is required for handling claims.

3. In the case of damage or loss to the equipment, WCB may perform three major functions:

- **Manufacturer Function** - WCB manufactures quality equipment and stands behind the WCB Standard Warranty. Refer to the Standard Warranty.
- **Assessor Function** - WCB offers assessment services for filing claims. The WCB assessor will accurately determine the extent of the damage (or loss), and cost of repairs to the equipment. Reimbursement for this service will be agreed upon prior to the assessment.
- **Repair House Function** - WCB offers services for repairing the damage(s) or replacement of loss(es) to the equipment. WCB has the option to alter the Standard Warranty on refurbished or replacement parts. The cost of this service will be dependent upon the assessment that is made.

Pump Characteristics

The Waukesha 200 Series Pump is built for extremely durable service. The casing, backplate and impeller/stub shaft are cast 316L stainless steel for extra strength and resistance to line shock and corrosion. Large bearings and shaft provide positive alignment and minimize vibration.

The casing is clamped to the motor adapter bracket (close coupled) or bearing housing (base mount) for easy disassembly while permitting 360 degree rotation of the discharge port.

200 Series pumps are available with three standard seal types.

- **Type 1**- Single mechanical seal, external mounted and balanced.
- **Type 1C**- Single mechanical seal with water cascade flush.
- **Type 4** - Double mechanical seal with flush housing.

All seal components are interchangeable between models. All seal assemblies utilize an externally mounted, balanced rotary seal for longer seal life and better sealing capability. The stationary seal face is reversible and replaceable.

200 Series pumps are designed for a broad range of sanitary and industrial applications. Sanitary models are designed for clean-in-place and meet U.S.D.A. and 3A Standards.

200 Series Base Mount Description

The Waukesha 200 Series Modular Base Mounted Centrifugal Pump design consists of four components (in addition to pump and motor). These components are used in various combinations and arrangements to provide flexibility to meet various needs.

Base Mount Components

Bearing Housing (Pump Adapter)

- Bearing housing is made of epoxy coated cast iron w/316 SS shaft, ball bearings.
- The adapter mounts to the pump components (same components used for close coupled pumps).
- Bearing housing also includes coupling for motor shaft plus guards used in style "B" & "C" arrangements.

Style "B" Arrangement

The style "B" arrangement is composed of the bearing housing, motor adapter and base with stand attached to bearing housing; for use with NEMA C-face motors. All motors must have feet for attachment of supports. (Figure 1).

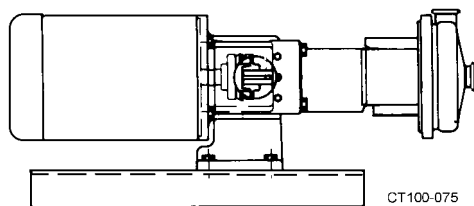

Figure 1 - Style B

Style "C" Arrangement

The style "C" arrangement is composed of the bearing housing and base with stand attached to bearing housing; for use with foot mounted T-frame motors. Pump and motor are mounted and supported independently. (Figure 2).

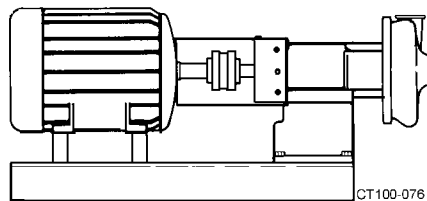

Figure 2 - Style C

Motor Adapter

- The motor adapter is made of epoxy coated cast iron.
- The motor adapter is used to mount a std. NEMA C-face motor onto bearing housing.
- The motor adapter is used to provide an accurate, rigid shaft alignment.
- The motor adapter is used in style "B" arrangements.

Stand

- The stand (pedestal) is made of epoxy coated cast iron.
- The stand attaches under motor adapter or bearing housing.

Base (Optional)

- The epoxy coated channel base - used in style "B" & "C" arrangements. See "Table of Base Size Used On Modular Base Mounted Centrifugal Pumps" on page 19.

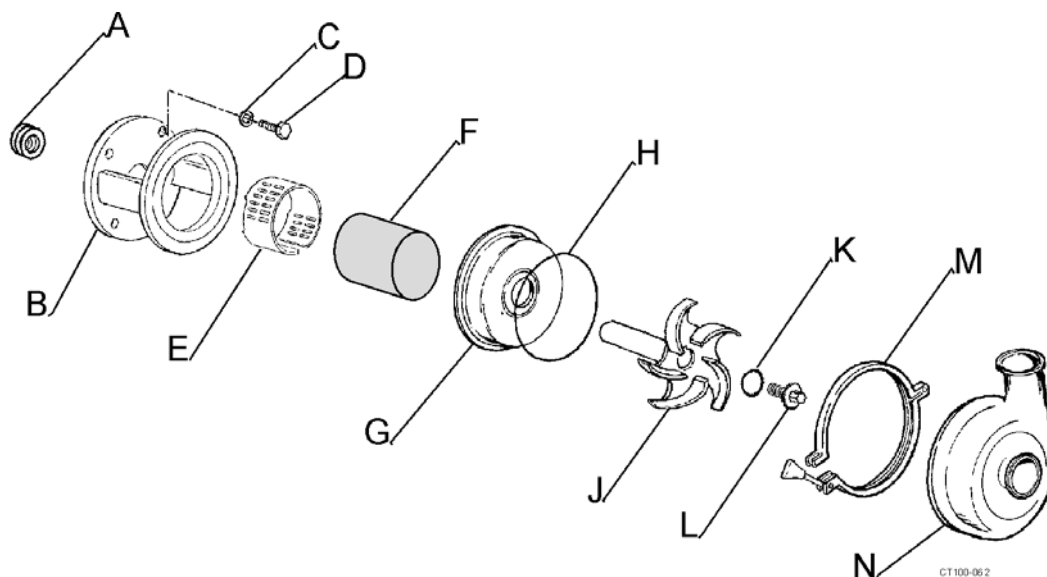

Figure 3 - Common Part Identification

A. Motor Shims	H. O-ring
B. Motor Adaptor	J. Impeller
C. Lock Washer	K. O-ring
D. Cap Screws	L. Impeller Retainer
E. Seal Guard	M. Clamp
F. Seals (detail not shown)	N. Casing
G. Backplate	

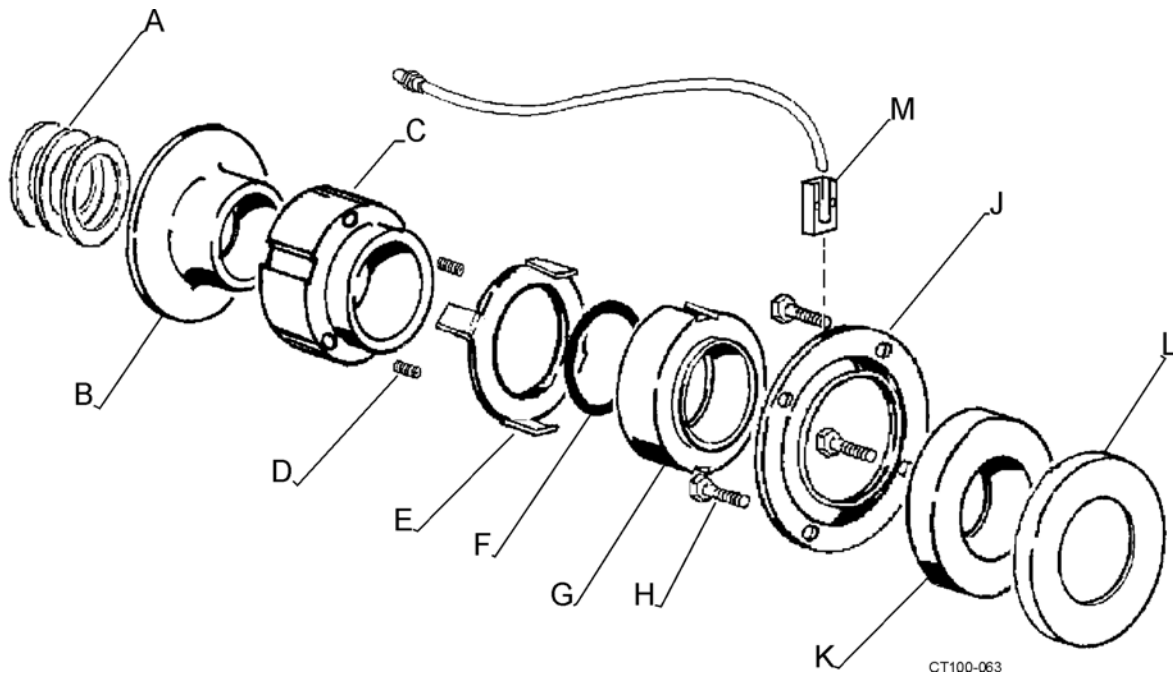

Figure 4 - Type 1 Seal Assembly (Water Cascade Type 1C)

- | | |
|--------------------|------------------------|
| A. Motor Shims | G. Rotary Seal |
| B. Deflector | H. Cap Screws |
| C. Spring Retainer | J. Seat Retainer |
| D. Springs | K. Stationary Seal |
| E. Tabbed Washer | L. L-gasket |
| F. O-ring | M. Water Cascade Block |

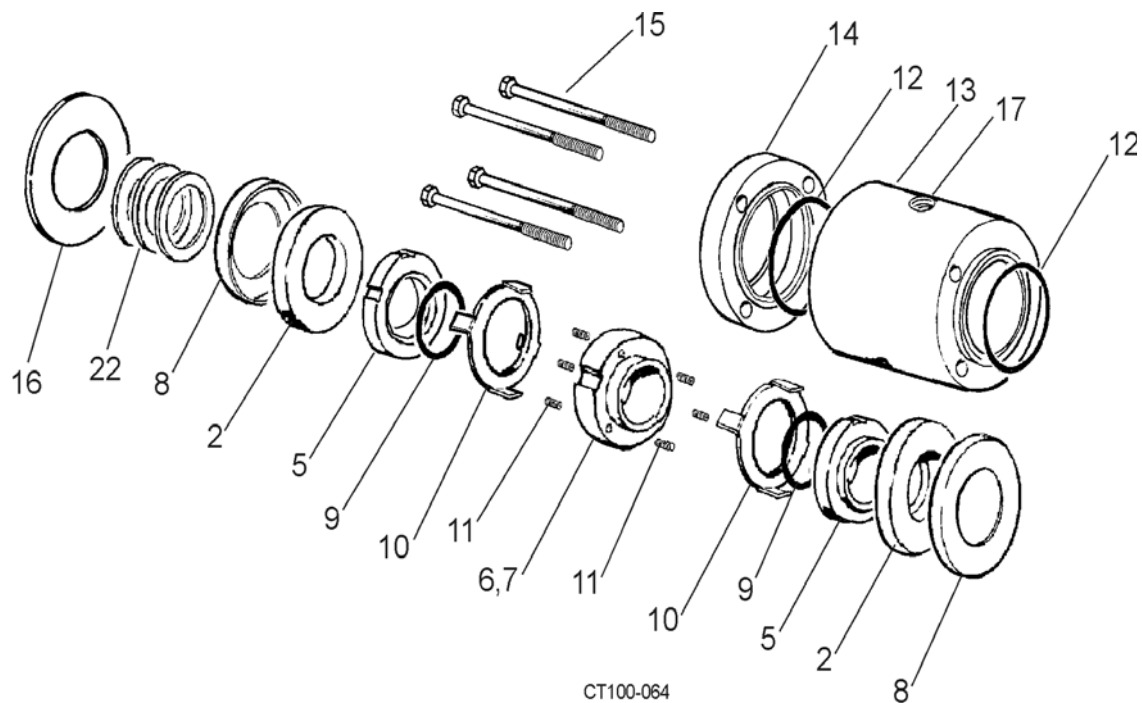

Figure 5 - Type 4 Seal Assembly

A. Motor Shims	L. Tabbed Washer
B. Slinger	M. O-ring
C. L-gasket	N. Rotary Seal
D. Stationary Seal	P. Stationary Seal
E. Rotary Seal	R. L-gasket
F. O-ring	S. O-ring
G. Tabbed Washer	T. Housing
H. Springs	U. O-ring
J. Spring Retainer	V. Seat Retainer
K. Springs	W. Cap Screws

Performance Characteristics

Quality Control

Each pump undergoes a performance test for design flow rate and design pressure prior to shipment.

Authorization

3A/USDA (Sanitary Models)/EHEDG

Standard Construction

- Casing: 316L Stainless Steel.
- Port Connections: S-Line.
- Backplate: 316L Stainless Steel.
- Impeller W/Integral Shaft: 316L Stainless Steel.
- Impeller Retainer: 316L Stainless Steel.
- Shaft Seal: Single Mechanical, external balanced (Type 1).
- Rotary Seal Material: Carbon.
- Stationary Seal: Siliconized Graphite.
- Elastomers: FDA approved FKM.
- Finish: All product contact surfaces provided with a sanitary polish (150 Grit). Industrial, pumps are unpolished.
The motor adapter bracket is painted with a cast iron paint. This paint is a two-part epoxy, TNEMEC 104, Sky-Blue #104-BB-42 - on motor bracket and motor (if ordered).
- Mounting: Close coupled for JM shafted motors.

Construction Options

Ports

Bevel Seat
Female I-Line
Male I-Line
Q-Line
Butt-weld
Female or Male N.P.T
150 Lb. Flange, DIN or SMS

Seal Type

- Water Cascade (Type 1C).
- Double Mechanical w/flush (Type 4 Shaft Seal).
- WFI - Special Type 4 shaft seal for water for injection applications.
- Aseptic Shaft Seal - barrier flush design.
- Commercially available seals (Contact your WCB representative for details).

Rotary Seal Material

Purebide
Silicone Carbide
Tungsten Carbide

Stationary Seal

Silicone Carbide
Tungsten Carbide

Elastomers

EPDM (FDA approved)
Silicone (FDA approved)
Teflon Encapsulated (FDA approved)
FFKM

Finishes/Product Contact Surfaces

25RA
20RA
Electropolish
Unpolished -Industrial

Leg Kit

See "Motor Mounts" on page 68.

Base Mounting

Footless C-face motors
Footed C-face motors
T-Frame motors

NOTE: T-Frame motors can be configured with or without bases, couplings or coupling covers.

Pedestal Mounted

Two types on stands see "Base Mount Components" on page 9.

Motors

NEMA JM (standard) totally enclosed fan cooled (TEFC) for close-coupled pumps.

1750 or 3500 RPM single phase 115/230 volt and 3 phase 230/460 volt.

Optional Enclosures

Washdown
Explosion proof
Severe Duty/Chemical Duty

Operating Parameters

Nominal Capacity

Up to 1150 U.S. GPM (260 Cubic Meters/Hr.)

Viscosity

Up to 1500 CPS

Differential Pressure

UP to 340 Feet (100 Meters)

Temperature

Up to 450°F (230°C)

Nominal Speeds

1450 or 2900 RPM - 50HZ
1750 or 3500 RPM - 60HZ

Capacities

SANITARY MODEL	INLET SIZE INCH (MM)	OUTLET SIZE INCH (MM)	MAXIMUM CAPACITY GPM (M3/HR)
2045	1.5 (40)	4.5 (115)	190 GPM (43)
	2.0 (50)	4.5 (115)	190 GPM (43)
2065LV	1.5 (40)	6.5 (165)	200 GPM (45)
	2.0 (50)	6.5 (165)	200 GPM (45)
	2.5 (65)	6.5 (165)	200 GPM (45)
2065	2.5 (65)	6.5 (165)	400 GPM (91)
2065HV	3.0 (75)	6.5 (165)	500 GPM (114)
2075	3.0 (75)	8.5 (215)	143 GPM (33)
2085LV	2.0 (50)	8.5 (215)	143 GPM (33)
2085	3.0 (75)	8.5 (215)	840 GPM (191)
	4.0 (100)	8.5 (215)	840 GPM (191)
2105	4.0 (100)	10.5 (265)	1400 GPM (318)
	6.0 (150)	10.5 (265)	1400 GPM (318)

Dimensions

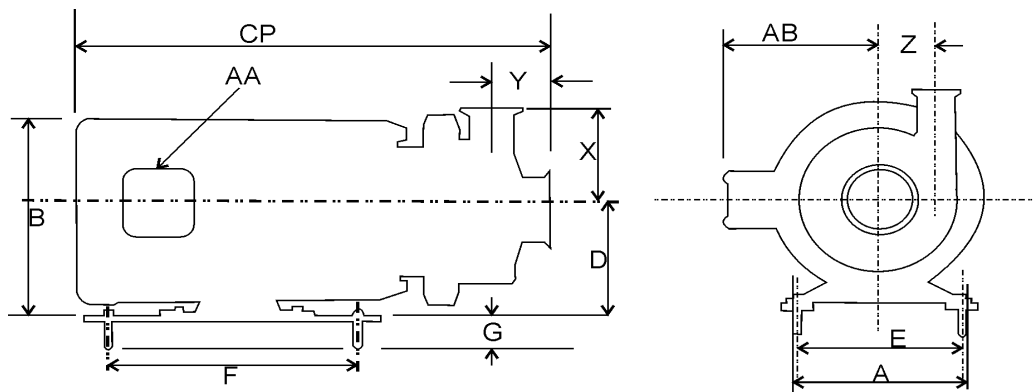

Figure 6 - Foot Print Dimensions

SANITARY MODEL SIZE (INLET X OUTLET)

Motor Frame	2045 All	2065LV All	2065 2-1/2x2	2065HV 3x2	2085LV 2x1-1/2	2075 2x1-1/2	2085 3x2-1/2	2085 4x2-1/2	2105 4x4	2105 6x4
Dim. Callout	CP inch (mm)	CP inch (mm)	CP inch (mm)	CP inch (mm)	CP inch (mm)	CP inch (mm)	CP inch (mm)	CP inch (mm)	CP inch (mm)	CP inch (mm)
145JM	18.94 (481)	16.35 (415)	16.94 (430)	17.04 (433)	16.16 (410)	16.16 (410)	17.50 (445)	17.05 (433)		
182JM	21.81 (554)	19.66 (500)	20.25 (514)	20.35 (517)	18.09 (459)	18.09 (459)	19.43 (494)	18.96 (482)		
184JM		19.66 (500)	20.25 (514)	20.35 (517)	18.09 (459)	18.09 (459)	19.43 (494)	18.96 (482)	25.13 (638)	25.16 (639)
213JM		21.91 (557)	22.50 (572)	22.60 (574)	21.72 (552)	21.72 (552)	23.05 (585)	22.55 (573)	23.88 (607)	23.91 (607)
215JM		21.91 (557)	22.50 (572)	22.60 (574)	21.72 (552)	21.72 (552)	23.05 (585)	22.55 (573)	26.56 (675)	26.59 (675)
254JM		25.47 (647)	26.06 (662)	26.17 (665)	25.53 (648)	25.53 (648)	26.87 (682)	26.43 (671)	27.63 (702)	27.66 (703)
256JM			27.81 (706)	27.92 (709)	25.53 (648)	25.53 (648)	26.87 (682)	26.43 (671)	29.38 (746)	29.41 (747)
284JM				28.44 (722)	27.66 (703)	27.66 (703)	29.00 (737)	28.50 (724)	29.94 (760)	29.97 (761)
286JM				29.94 (760)	29.16 (791)	29.16 (791)	30.50 (775)	30.00 (762)	31.44 (799)	31.47 (799)
324JM					29.97 (761)	29.97 (761)	31.31 (795)	30.81 (782)	31.63 (803)	31.66 (804)
326JM					31.47 (799)	31.47 (799)	32.81 (833)	32.31 (821)	32.87 (835)	32.91 (836)

TABLE OF DIMENSIONS

Frame	A inch (mm)	B inch (mm)	D inch (mm)	AA inch (mm)	AB inch (mm)	F inch (mm)	E inch (mm)	G inch (mm)
145JM	8.56 (218)	6.87 (174)	3.5 (89)	.50 (13)	5.25 (133)	12.50 (317)	5.50 (140)	2.00 (51)
182JM	9.81 (249)	8.44 (214)	4.50 (114)	.75 (19)	5.87 (149)	12.50 (317)	7.50 (190)	
184JM	9.81 (249)	8.44 (214)	4.50 (114)	.75 (19)	5.87 (149)	12.50 (317)	7.50 (190)	
213JM	12.18 (309)	10.06 (256)	5.25 (133)	.75 (19)	7.38 (187)	12.50 (317)	8.25 (209)	
215JM	12.18 (309)	10.06 (256)	5.25 (133)	.75 (19)	7.38 (187)	16.0 (406)	8.25 (209)	
254JM	14.68 (373)	12.0 (305)	6.25 (159)	1.0 (25.4)	8.94 (227)	16.0 (406)	10.0 (254)	
256JM	14.68 (373)	12.0 (305)	6.25 (159)	1.0 (25.4)	8.94 (227)	25.5 (648)	10.0 (254)	2.50 (64)
284JM	18.87 (225)	13.63 (346)	7.0 (178)	1.5 (38)	12.25 (311)	25.5 (648)	11.0 (279)	
286JM	18.87 (225)	13.63 (346)	7.0 (178)	1.5 (38)	12.25 (311)	25.5 (648)	11.0 (279)	
324JM	20.75 (527)	15.56 (395)	8.0 (203)	1.5 (38)	13.18 (335)	25.5 (648)	12.5 (317)	
326JM	20.75 (527)	15.56 (395)	8.0 (203)	1.5 (38)	13.18 (335)	25.5 (648)	12.5 (317)	

NOTE: Figure 6 dimensions for the Inlet, Outlet, items X,Y and Z are listed in Table on page 17.

TABLE OF DIMENSIONS

Model (**)	Inlet inch (mm)	Outlet inch (mm)	X inch (mm)	Y inch (mm)	Z inch (mm)
2045	1.5 (40)	1.5 (40)	3.88 (98)	1.81 (46)	2.25 (57)
2045	2.0 (50)	1.5 (40)	3.88 (98)	1.81 (46)	2.25 (57)
2065LV	1.5 (40)	1.5 (40)	4.75 (120)	1.94 (49)	3.19 (81)
2065LV	2.0 (50)	1.5 (40)	4.75 (120)	1.94 (49)	3.19 (81)
2065LV	2.5 (65)	1.5 (40)	4.75 (120)	1.94 (49)	3.19 (81)
2065	2.5 (65)	2.0 (50)	4.44 (113)	1.94 (49)	3.94 (100)
2065HV	3.0 (75)	2.0 (50)	4.44 (113)	1.94 (49)	3.94 (100)
2075	3.0 (75)	1.5 (40)	6.69 (170)	1.75 (44)	4.5 (114)
2085LV	2.0 (50)	1.5 (40)	6.69 (170)	1.75 (44)	4.5 (114)
2085	3.0 (75)	2.5 (65)	5.63 (143)	2.53 (64)	5.06 (129)
2085	4.0 (100)	2.5 (65)	5.63 (143)	2.03 (52)	5.06 (129)
2105	4.0 (100)	4.0 (100)	6.94 (176)	2.86 (73)	6.75 (171)
2105	6.0 (150)	4.0 (100)	6.94 (176)	2.90 (74)	6.75 (171)

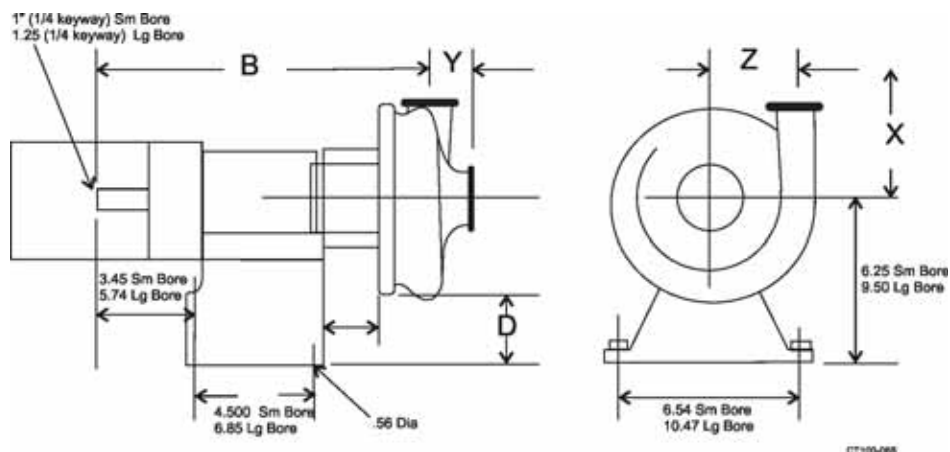

Figure 7 - Style "B" and "C" Less Base Plate

Model	B				D		X inch	Y inch	Z inch
	Inlet inch (mm)	Outlet inch	Sm Bore inch	Lg Bore inch	Sm Bore inch	Lg Bore inch			
P2045	1.5 (40)	1.5 (40)	16.39 (416)	---	3.0 (76)	---	3.88 (98)	1.81 (45)	2.25 (57)
P2045	2.0 (50)	1.5 (40)	16.39 (416)	---	3.0 (76)	---	3.88 (98)	1.81 (45)	2.25 (57)
P2065LV	1.5 (40)	1.5 (40)	16.71 (224)	---	2.0 (50)	5.2 (132)	4.75 (120)	1.94 (49)	3.19 (81)
P2065LV	2.0 (50)	1.5 (40)	16.71 (224)	---	2.0 (50)	5.2 (132)	4.75 (120)	1.94 (49)	3.19 (81)
P2065LV	2.5 (65)	1.5 (40)	16.71 (224)	---	2.0 (50)	5.2 (132)	4.75 (120)	1.94 (49)	3.19 (81)
P2065	2.5 (65)	2.0 (50)	17.30 (439)	---	2.0 (50)	5.2 (132)	4.44 (112)	1.94 (49)	3.94 (100)
P2065HV	3.0 (75)	2.0 (50)	17.93 (455)	21.30 (541)	2.0 (50)	5.2 (132)	4.44 (112)	1.94 (49)	3.94 (100)
P2075	3.0 (75)	1.5 (40)	17.19 (436)	20.42 (581)	1.0 (25)	4.2 (106)	6.69 (176)	1.75 (44)	4.50 (114)
P2085LV	2.0 (50)	1.5 (40)	17.19 (436)	20.42 (581)	1.0 (25)	4.2 (106)	6.69 (176)	1.75 (44)	4.50 (114)
P2085	3.0 (75)	2.5 (65)	18.41 (467)	21.90 (556)	1.0 (25)	4.2 (106)	5.63 (143)	2.53 (64)	5.06 (128)
P2085	4.0 (100)	2.5 (65)	17.91 (454)	21.40 (543)	1.0 (25)	4.2 (106)	5.63 (143)	2.03 (51)	5.06 (128)
P2105	4.0 (100)	---	---	22.57 (573)	---	3.2 (81)	6.94 (176)	2.86 (72)	6.75 (171)
P2105	6.0 (150)	---	---	22.60 (574)	---	3.2 (81)	6.94 (176)	2.90 (73)	6.75 (171)

NOTE: Dimensions X,Y, B apply to pumps with clamp connections.

TABLE OF BASE SIZE USED ON MODULAR BASE MOUNTED CENTRIFUGAL PUMPS

Motor HP & RPM	Sanitary Models							
	P2045	P2065LV	P2065	P2065HV	P2075	P2085LV	P2085	P2105
Up to 5HP 1750 RPM	SM.B.	SM.B.	SM.B.	SM.B.	SM.B.	SM.B.	SM.B.	SM.B.
Up to 5HP 3500 RPM	SM.B.	SM.B.	SM.B.					
7½HP 1750 RPM							SM.B.	L.G.B.
7½HP 3500 RPM		SM.B.	SM.B.	SM.B.	SM.B.	SM.B.	SM.B.	
10HP 1750 RPM							SM.B.	L.G.B.
10HP 3500 RPM		SM.B.	SM.B.	SM.B.	SM.B.	SM.B.	SM.B.	
15HP 1750 RPM								L.G.B.
15HP 3500 RPM			SM.B.	SM.B.	SM.B.	SM.B.	SM.B.	
20HP 1750 RPM								L.G.B.
20HP 3500 RPM			SM.B.	SM.B.	SM.B.	SM.B.	SM.B.	
25HP 1750 RPM								L.G.B.
25HP 3500 RPM				L.G.B.				L.G.B.
30HP 1750 RPM								L.G.B.
30HP 3500 RPM				L.G.B.			L.G.B.	
40HP 1750 RPM								L.G.B.
40HP 3500 RPM							L.G.B.	
50HP 1750 RPM								L.G.B.
50HP 3500 RPM							L.G.B.	
60HP 3500 RPM							L.G.B.	
75HP 3500 RPM							L.G.B.	

SM.B. = Small Base

L.G.B. = Large Base

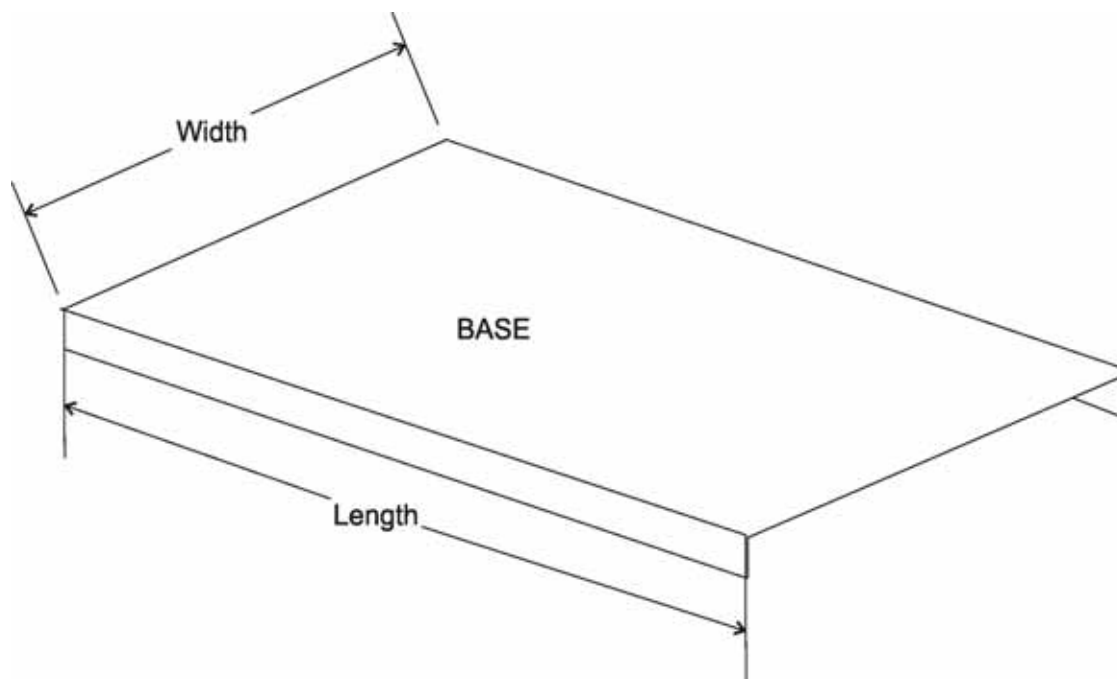

Figure 8 - Base Plate Dimensions for Modular Base Mounted Centrifugal Pumps

Base plates (optional) are provided in three widths and five lengths (depending on motor frame and pump model).

Widths Available

10 inches
15 inches
18 inches

Lengths Available

20 inches (Style A Only)
24 inches
32 inches
38 inches
50 inches

Centrifugal 200 Series Pump and Pedestal Weights

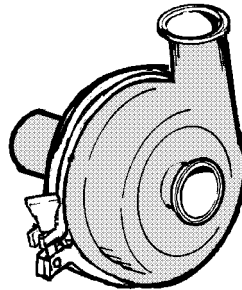

Figure 9 - Close Coupled Pump (Less Motor and Legs)

Motor Frame	Pump Model							
	2045 LBS (KG)	2065LV LBS (KG)	2065 LBS (KG)	2065HV LBS (KG)	2075 LBS (KG)	2085LV LBS (KG)	2085 LBS (KG)	2105 LBS (KG)
142-184JM	21 (9.5)	31 (14)	33 (14.9)	35 (15.8)	57 (25.8)	57 (25.8)	51 (23.1)	60 (27.2)
213-215JM	35 (15.8)	37 (16.7)	39 (17.6)	60 (27.2)	54 (24.4)	54 (24.4)	78 (35.3)	
254-256JM	37 (16.7)	39 (17.6)	41 (18.5)	63 (28.5)	57 (25.8)	57 (25.8)	79 (35.8)	
284-326JM	51 (23.1)	53 (24)	71 (32.2)	64 (29)	82 (37.1)	82 (37.1)		

Add 5LB. For Pumps With Double Seals

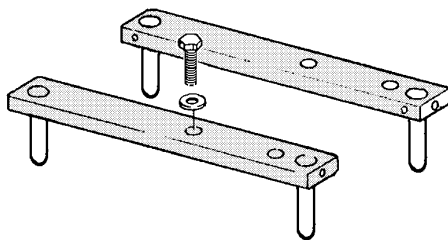

Figure 10 - Legs

ADD LISTED WEIGHT FOR LEGS

Motor Frame	Weight LBS (KG)
142-213JM	10.5 (4.7)
215-254JM	12.5 (5.6)
254-326JM	42.5 (19.2)

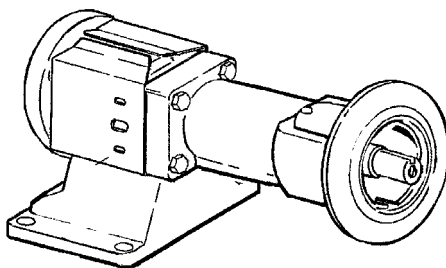

Figure 11 - Pedestal Pump (Less Base and Motor)

PUMP MODEL								
PEDESTAL	2045 lbs (KG)	2065LV lbs (KG)	2065 lbs (KG)	2065HV lbs (KG)	2075 lbs (KG)	2085LV lbs (KG)	2085 lbs (KG)	2105 lbs (KG)
SMALL BORE	92 (41)	106 (48)	108 (48.9)	110 (49.8)	131 (59.4)	131 (59.4)	125 (56.6)	
LARGE BORE							235 (106.5)	240 (108.8)

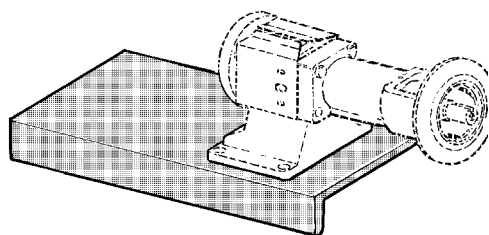

Figure 12 - Base Weight (Add to Pedestal Weight)

MOTOR	SMALL BORE LBS (KG)	LARGE BORE LBS (KG)
48	30 (13.6)	
56	30 (13.6)	
143/145T	31 (14.6)	
182/184T	32 (14.5)	50 (22.6)
213/215T	33 (14.9)	50 (22.6)
254/256T	40 (18.1)	52 (23.5)
284/286T	35 (15.8)	62 (28.1)
284/286TS		64 (29.0)
324/326T		65 (29.4)
324/326TS		65 (29.4)
364TS		65 (29.4)

Installation

Unpack all parts of your equipment and inspect for damages that may have occurred during shipping. Report any damage to the carrier.

All ports are covered at the factory to keep out foreign objects during transit. If the covers are missing or damaged, remove the pump cover and thoroughly inspect the fluid head. Be sure the pump head is clean and free of foreign material before rotating shaft.

Pump Location

The following considerations should be addressed when determining a location for the installation of your pump.

- Locate pump as near as practical to the liquid supply.
- Keep supply piping short and straight to keep pump supplied with liquid and prevent damaging cavitation.
- Pump should be accessible for service and inspection during operation.
- Motor must be protected from flooding.

Pump Leveling

Level the pump by loosening the set screws (Figure 1, item A) to adjust the length of the legs.

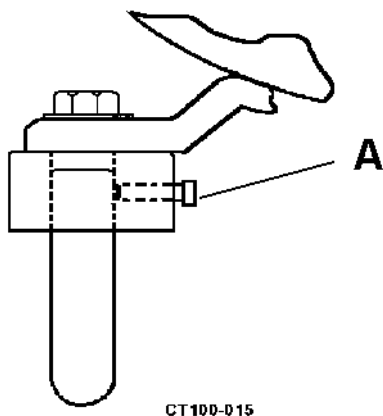

Figure 1 - Leveling Leg Set Screw Location

Supply and Discharge Piping/Valves

The following considerations should be addressed when determining supply/discharge piping and valve installation of your pump.

- Use line size equal to, or larger than, connection size on pump, especially the inlet supply line.
- Keep supply line as short and straight as possible and use as few elbows, valves or other types of restriction as possible. Avoid up and down rises which will trap air.
- Be certain all joints in the suction line are well sealed to prevent air leaks.
- Maintain a straight length of pipe (Figure 2, item A) at least 8 diameters long at the pump inlet.

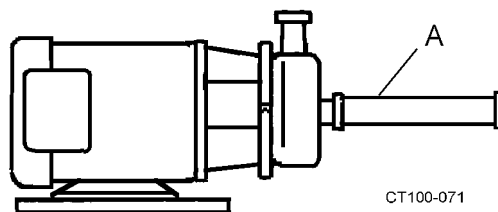

Figure 2 - Straight Pipe Length

- The pump casing may be rotated with the discharge connection pointing in any direction. The best pump performance will be with the outlet up, to the left or positions in between; these positions insure a flooded casing and prevent problems due to air in the system. (Figure 2).

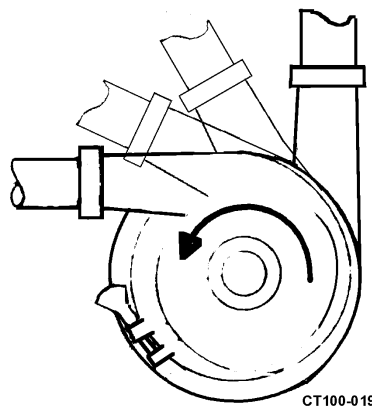

Figure 3 - Recommended Discharge Positions

- All joints in suction line must be well sealed to prevent air from being sucked into the system.
- Support supply and discharge piping near the pump so that no strain is put on the pump casing.

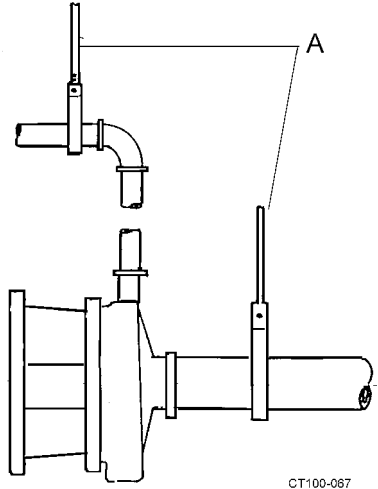

Figure 4 - Pipe Supports

- If an expansion joint is used, install a pipe anchor between the joint and the pump.
- If a reducer is connected to inlet, use eccentric type to prevent problems due to trapped air. (Figure 5).

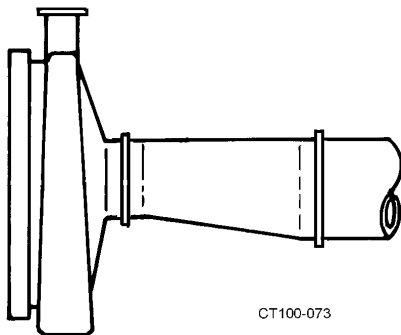

Figure 5 - Correct Eccentric Installation



CAUTION: The pump and piping may contain sharp edges. Wear gloves during installation and service of the pump to help avoid injuries from these hazards.

- Line slope will depend on application requirements; best pump operation is with supply line sloped slightly upward toward pump to prevent trapping air. If system must drain into pump casing, keep downward slope to a minimum or priming problems may occur.

- Install shutoff valves to isolate pump from supply and discharge lines. This will allow pump service without draining the system.
- This pump is not self priming. If pump is installed above supply liquid level, install foot valve or other system check valve to keep system flooded for priming. (Figure 6, item A).
- A throttling valve may be required to control pump flow rate to prevent motor overload. Always install throttling valve (Figure 6, item B) in discharge piping and at least 10 diameters from pump outlet.
- **Never** install throttling valve in supply piping. (Figure 6, item C).

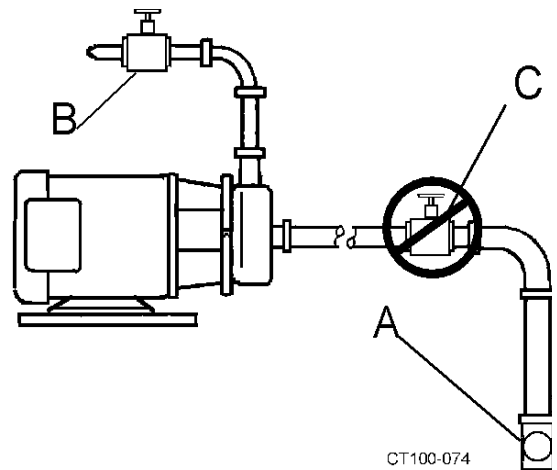

Figure 6 - Valve Piping Installation

Installations That May Cause Operation Problems

- Any system throttling valves or similar devices to control flow rate must be installed in the discharge line. **Do not** install any system throttling valves or similar devices to control flow rate in the supply line. Restriction in the supply line may cause cavitation and pump damage.
- "Water hammer" in the system can damage the pump and other system components. Water hammer often occurs when valves in the system are suddenly closed causing lines to move violently and with a loud noise. When this condition is present, find and eliminate the source of the water hammer. One way to eliminate water hammer is to slow down the actuation speed of the valve.
- Do not expose pump to freezing temperatures with liquid in casing. Frozen liquid in casing will damage pump. Drain casing before exposing to freezing temperatures.

Electrical Connections

WARNING: To avoid electrocution, ALL electrical installation should be done by a registered Electrician, following Industry Safety Standards. All power must be OFF and LOCKED OUT during installation.

- Read motor manufacturer's instructions before making installation. Follow manufacturer's lubrication schedules.
- Check motor nameplate to be sure motor is compatible with electrical supply and all wiring, switches, starters. Make sure all overload protections are correctly sized. (Figure 7).

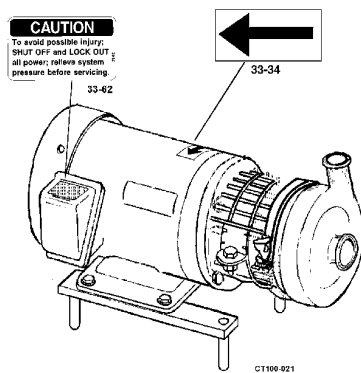

Figure 7 - Replaceable Label Location

- Check pump rotation following electrical installation. Correct rotation is counterclockwise when facing pump inlet connection. (Figure 3) and Figure 7.

Flush Seal Option

When this option is ordered, a fitting assembly (Part Number 60112) (Figure 8, item B) is supplied for directing a flow of water onto the backplate/seal area.

- The water cascade block (Figure 8, item A) must be above the seal on the assembled backplate to flow water onto the seal face.
- The connection is 1/4 inch O.D. tubing.
- Required flow is approximately 5 U.S. gallons per hour.
- The recommended water supply is cool and filtered. If product solidifies at cool temperature, warm or hot water can be used.

NOTE: To prevent hose contact with rotating shaft and seal parts during operation, pull excess hose to outside of seal guard.

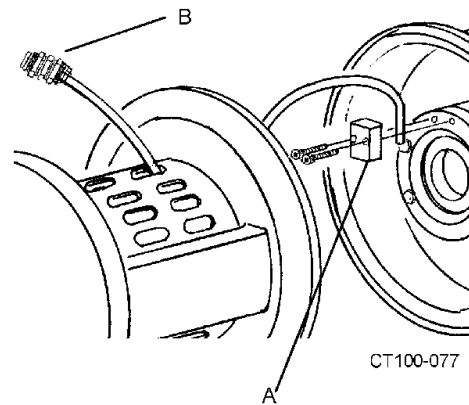

Figure 8 - Cascade System Installation

Type 4 Seal

(Double mechanical with flush)

Attach seal flush supply to the bottom 1/4-inch pipe threaded hole in the flush housing. Drain tubing attached to the top hole allows moderate pressure to be supplied to the seals and continuous flooding. (Figure 9).

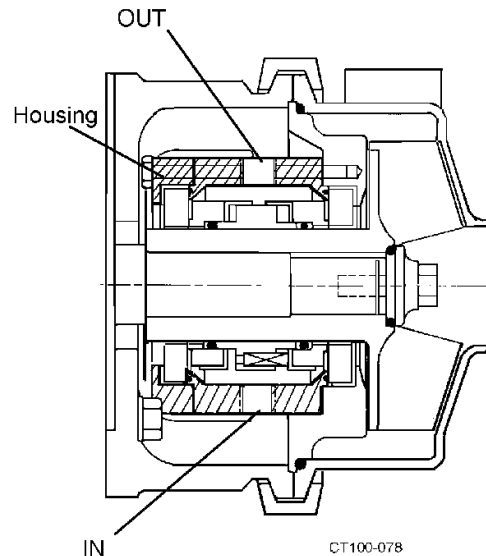

Figure 9 - Type 4 Flush Housing

Before First Startup

Clean Pump and Piping

Disassemble pump and clean all product contact parts and seal parts prior to first operation. Follow instructions in the “Cleaning Safety Procedures” on page 26 and “Routine Maintenance” on page 29. The pump should be thoroughly cleaned of any materials which could have accumulated during installation.

Cleaning Safety Procedures

Manual Cleaning

The following considerations should be addressed when manually cleaning your pump.

- Do not use toxic and/or flammable solvents.
- Lock out electrical power and shut off all air prior to cleaning equipment.
- Keep electrical panel covers closed and power off when washing equipment.



WARNING: To prevent an accidental start-up the power source should be locked out using your lock and key.

- Clean up spills as soon as possible.
- Never attempt cleaning equipment while it is operating.
- Wear proper protective clothing.

Cleaning-In-Place (CIP)

When performing CIP do the following:

1. Make certain that all connections in cleaning circuit are properly applied and tight to avoid contact with hot water or cleaning solutions.
2. When cleaning cycle is controlled from remote or automated cleaning center, establish safe procedures to avoid automatic start-up while servicing equipment in the circuit.

Preliminary Test Run

The system should be tested using a preliminary run with the materials that will be pumped. **DO NOT** run the pump at this time to produce final product.

See “Starting the Pump” on page 27.

Check For Possible Motor Overload Conditions

Certain combinations will overload motor when operated with open unrestricted discharge which results in too high flow rate. Additional discharge restriction may be required to lower flow rate and lower horsepower requirement. **DO NOT** add restriction to supply line. If pump was incorrectly selected, a smaller impeller may be required or a higher motor horsepower may be required.

If uncertain about pump selection and application, temporarily install an ammeter in the electrical service.

Ammeter Test



WARNING: To avoid electrocution and equipment damage, only a qualified electrician should install the ammeter.

Operate pump under process conditions and check motor amp draw versus nameplate full load rating. If amp draw exceeds motor rating, a system change or pump change is required.

If process conditions and/or liquid changes (higher viscosity, higher specific gravity) recheck motor amp draw.

Operation

Before proceeding make sure your pump has been correctly installed as described in “Installation” on page 23.

Starting the Pump

The following is the procedure for starting the pump.

1. If pump has the flush seal option, start flow of flush water (approximately 5 US gallons per hour recommended rate) before operating the pump.
2. Prime the pump by flooding the pump casing with liquid **BEFORE** starting pump to avoid damage to pump parts. See “Priming the Pump With the Feed Source Above Pump Level” on page 27 or “Priming the Pump With the Feed Source Below Pump Level” on page 27.
3. Start pump motor.
4. Check the pump to see that liquid is flowing and that all piping connections and seals are leak free.
5. Make sure that the pump is not operating against a closed discharge. Continued operation against a closed discharge will heat liquid in casing to boiling and lead to pump damage.
6. Slowly open discharge valve until desired flow is obtained. Observe pressure gauges and if pressure is not attained quickly, stop pump and prime again.

Priming the Pump

Priming the Pump With the Feed Source Above Pump Level

1. Fill supply tank with liquid; open supply line valve (suction) (Figure 1, item B).
2. Vent any air trapped in supply line or casing by opening the discharge valve. (Figure 1, item A).

3. Start the pump.

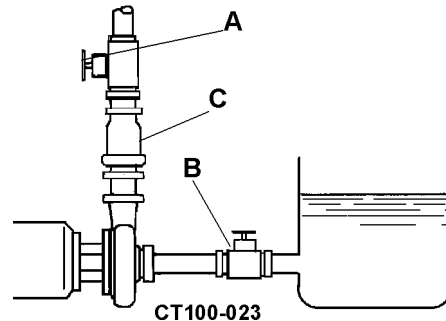

Figure 1 - Pump Below Supply

Priming the Pump With the Feed Source Below Pump Level

The pump will not self prime if liquid supply is below pump level. When liquid supply is below pump level an outside source must be provided for priming.

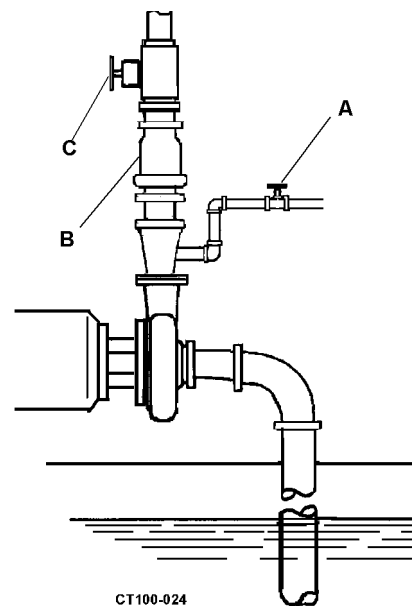

Figure 2 - Pump Above Supply

1. Close discharge valve (Figure 2, item C) and open air vents.

2. Open the valve installed in the outside supply line (Figure 2, item A) until liquid flows from vent valves.
3. Close vent valves.
4. Close outside supply line.

***NOTE:** Use a check valve system (Figure 2, item B) to keep supply line and pump casing flooded with liquid. Otherwise the pump must be primed before each operation.*

Stopping the Pump

1. To stop pump, shut off power to pump motor.

***NOTE:** Liquid in system can flow freely through the pump; the pump does not act as a shutoff valve.*

2. Shut off supply and discharge lines.

Maintenance

Scheduled Maintenance

A routine maintenance program can extend the life of your pump. Make sure to keep maintenance records. These records will help pinpoint potential problems and causes.

Routine Maintenance

Your scheduled routine maintenance should include the following items:

- Check for unusual noise, vibration and bearing temperatures.
- Inspect pump and piping for leaks.
- Check Mechanical Seal area for leakage. No leakage is desired.
- Check backplate gasket for wear/damage.
- Bearing lubrication (See motor manufacturer for correct specifications).
- Seal Monitoring.
- Vibration analysis.
- Check discharge pressure.
- Temperature monitoring.

Disassembly of Pump With a Type 1 Seal

The following procedure covers the disassembly of a pump with a type 1 seal.

1. Shut off product flow to pump and relieve any product pressure.
2. Shut off and lockout power to pump.
3. Disconnect the suction and discharge pipe fittings.
4. Remove casing clamp and casing.
5. Slide O-ring off of backplate.
6. Remove impeller retainer bolt and shaft O-ring.

NOTE: Retainer bolt has standard right hand threads.

Removal of the Water Cascade

1. Loosen socket head screws holding water cascade block on the stationary seat retainer and remove plastic hose.

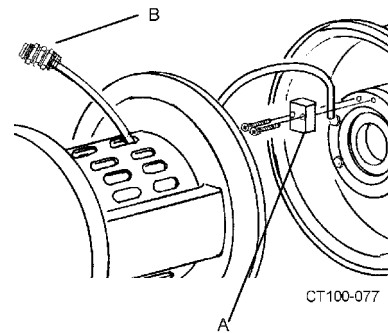

Figure 1 - Removal of the Water Cascade System

2. Pull off impeller/backplate assembly and place on a clean flat surface with impeller shaft up.

NOTE: If assembly cannot be removed from motor shaft by hand contact Waukesha Cherry-Burrell Customer Service.

3. Locate shims on motor shaft and remove.

NOTE: Motor shaft shims may fall off motor shaft or hang-up inside the deflector. **Be sure to place all shims back on motor shaft.**



CAUTION: Handle the impeller/backplate assembly with care to prevent damage to seal components.

4. Remove deflector. (Figure 2, item B).
5. Loosen set screws (2) (Figure 2, item D) in spring retainer (Figure 2, item C) and slide retainer and

washer (Figure 2, item F) off shaft. Save springs (3) (Figure 2, item E).

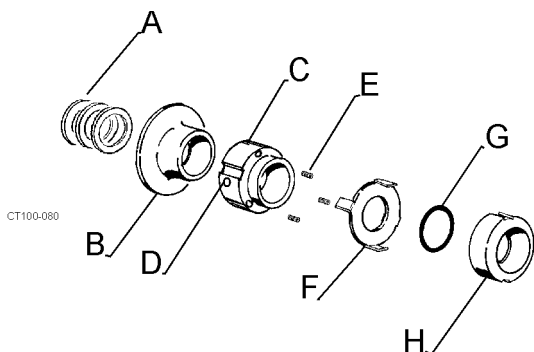

Figure 2 - Type 1 Seal Items

6. Use backplate to slide rotary seal up the impeller shaft approximately 1-1/2 inches. (Figure 3).



Figure 3 - Moving the Rotary Seal up the Shaft

7. With the backplate resting on the impeller, push the rotary seal toward the backplate until the O-ring is free. (Figure 4).



Figure 4 - Push Rotary Seal Down Until the O-ring is Released.

8. Remove O-ring, then lift rotary seal off shaft. (Figure 2, items G and H).

CAUTION: To avoid seal failure, **DO NOT** place fingers on the carbon seal face.

9. Lift the backplate off the impeller.

10. Remove four 1/4" hex bolts and stationary seat retainer ring. (Figure 5, items A and B).

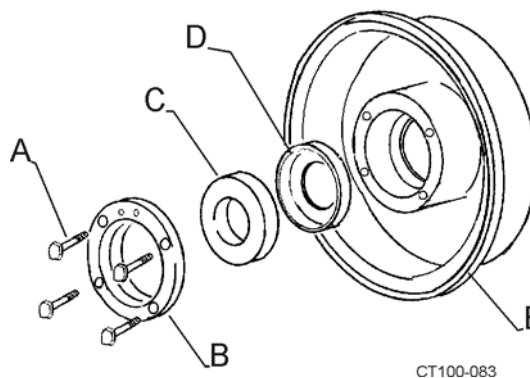

Figure 5 - Removing Stationary Seal

11. Pull the stationary seal and L-gasket out of backplate. (Figure 5, items C and D).

NOTE: The stationary seal is brittle. Prying or hammering on the seal plate can shatter the seal. If the stationary seal cannot be removed by hand, place a 2-1/4 inch diameter plastic or wood rod on the impeller side of the seal and apply even pressure to dislodge the seal.

Inspect Parts

Once disassembly is complete perform the following inspections.

- Examine all seal surfaces and replace seals that become scratched, cracked and/or braised.
- Inspect all O-rings and O-ring seats for abrasions, cuts or other wear that could cause leakage.
- Clean all seat areas and alignment surfaces.

NOTE: Stationary seals are **reversible**. Use **both sides** before replacing.

NOTE: Replace the rotary seal when the seal face extends less than 1/32 inch (1mm) from the body (Figure 6).

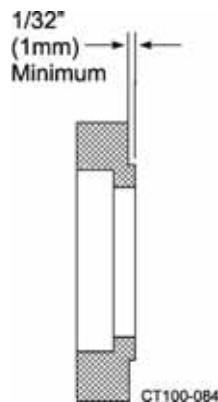

Figure 6 - Replace Rotary Seal if Less Than Minimum

Assembly of Pump With a Type 1 Seal

The following procedure covers the assembly of a pump with a Type 1 seal.

Backplate Assembly

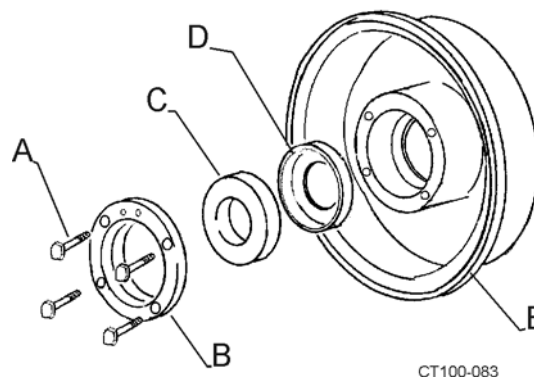

Figure 7 - Stationary Seal Assembly

1. Lightly lubricate both sides of the L-gasket (Figure 7, item D) with a sanitary lubricant and insert into the backplate seal cavity.
2. Place the stationary seal into the L-gasket. (Figure 7, items C and D).
3. Place the seat retainer over the stationary seal and secure retainer with four 1/4-20 x 1/2 inch hex head cap screws. (Figure 7, items B and A).
4. Tighten the cap screws evenly.

Backplate/Impeller Assembly

1. Place impeller on a clean flat surface, shaft end up, and slide the assembled backplate onto the impeller shaft.

NOTE: Avoid hitting the stationary seal against the impeller shaft. It could break the seal.

2. Carefully place the rotary seal in position over the impeller shaft and down against the stationary seal.

- Lubricate and slide the seal O-ring onto the impeller shaft. (Use the spring retainer as a tool to push the O-ring into the rotary seal). (Figure 19).

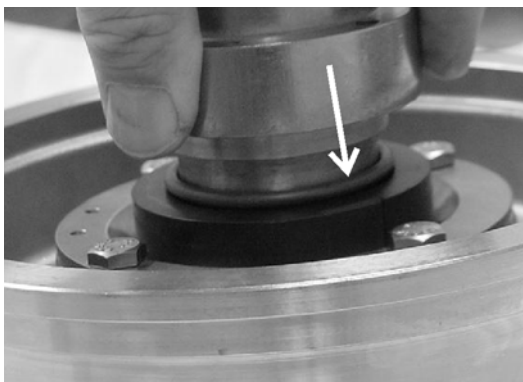

Figure 8 - Installing O-ring Using the Spring Retainer.

- Slide the tabbed washer (Figure 7, item F) over the impeller shaft and engage the tabs of the washer into notches on the outside of rotary seal. (Figure 9, items F and H).

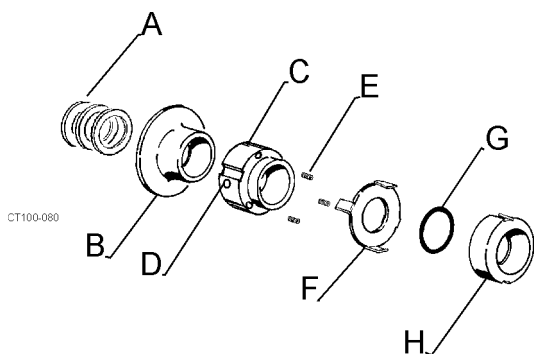

Figure 9 - Type 1 Seal Assembly

- Install the three seal springs into holes in the spring retainer. (Figure 9, items C and E). Hold the springs in place with RTV silicone sealant.
- Slide the spring retainer over the impeller shaft until the slots in the spring retainer engage the drive tabs on washer and springs rest against the washer. (Figure 9).
- With the backplate against the impeller, push the spring retainer down to compress the springs until the length of visible spring is approximately 1/8".

- Lock the spring retainer in place by tightening the set screws. (Figure 9, item D).
- Install the deflector on to the impeller shaft. (Figure 9, item B).
- If your system has a water cascade, thread water cascade hose through the guard and install cascade block on backplate. (Figure 10, items A and B).

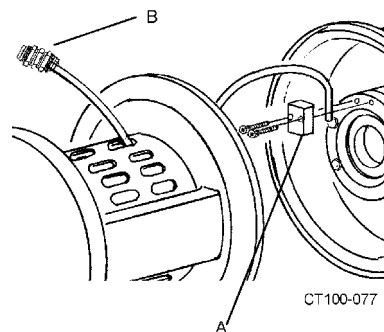

Figure 10 - Installing the Water Cascade System

- Slide the motor shims onto the shaft. The same number of shims that were removed when the pump was disassembled must be used.
- Install the impeller assembly on the stub shaft of the motor.
- Hand tighten the impeller retainer bolt on the shaft.
- Check the space between the back of the impeller and the backplate with a feeler gauge (.030 nominal) while holding the backplate tight against the bearing housing flange. (Any axial movement of the shaft should not be added to the .030 nominal clearance). (Figure 11). If needed, change this clearance by adding or removing shims. Shims (Figure 12, item A) are added on the drive shaft.

(Figure 12, item C) behind the impeller shaft (Figure 12, item B).

NOTE: Rotate impeller manually to insure it does not rub on the backplate or casing.

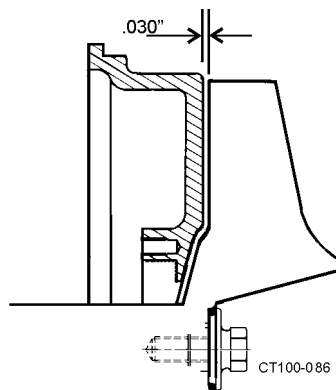

Figure 11 - Clearance Between Impeller and Backplate

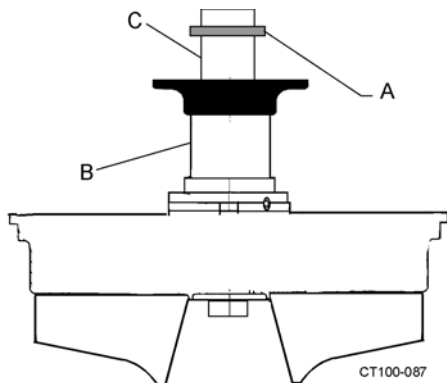

Figure 12 - Locations of Shims

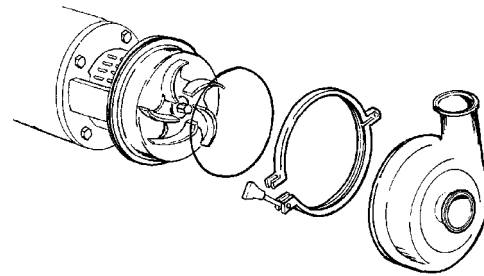
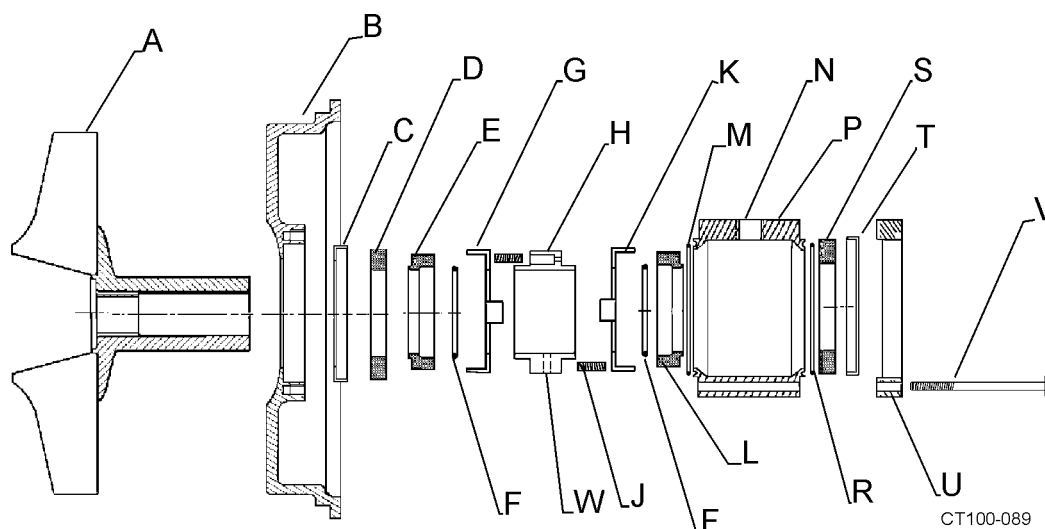

Figure 13 - Install Casing

15. Confirm operating clearances by clamping the casing to the bearing housing flange and rotating the bearing housing flange and rotating the shaft/impeller manually to be sure the impeller does not touch the casing or backplate.
16. When proper shim pack is confirmed remove the casing, impeller and backplate leaving the shim pack on the shaft.
17. Remove backplate/impeller assembly and apply anti-seize or equal compound to the motor shaft and install key.
18. Install casing O-ring on backplate and clamp casing in place. (Figure 13).

Type 4 Double Seal**Figure 14 - Type 4 Seal Components**

A. Impeller	F. O-ring	L. Rotary Seal	S. Stationary Seal
B. Backplate	G. Washer	M. O-ring	T. L-gasket
C. L-gasket	H. Spring Retainer	N. NPT Port	U. Seat Retainer
D. Stationary Seal	J. Spring	P. Flush Housing	V. Hex Head Screw (4)
E. Rotary Seal	K. Washer	R. O-ring	W. Set Screw

The Type 4 Seal is essentially two Type 1 seals assembled back to back in a chamber which bolts to the backplate in place of the stationary seat retainer. Except for the additional components, (e.g. chamber, seals) Type 1 and Type 4 components are interchangeable. (Figure 14).



CAUTION: Handle the impeller/backplate assembly with care to prevent damage to seal components.

Disassembly Type 4 Seal

The following procedure covers the disassembly of a pump with a Type 4 seal.

1. Shut off product flow to pump and relieve any product pressure.
2. Shut off and lockout power to pump.
3. Disconnect the suction and discharge pipe fittings.

4. Remove casing clamp and casing. Slide O-ring off of backplate.
5. Remove impeller retainer bolt and shaft O-ring.

NOTE: Retainer bolt has standard right hand threads.

Removal of the Water Cascade

If your system is equipped with a water cascade system, it is necessary to remove it before proceeding.

1. Loosen socket head screws holding water cascade block on the stationary seat retainer and remove plastic hose.

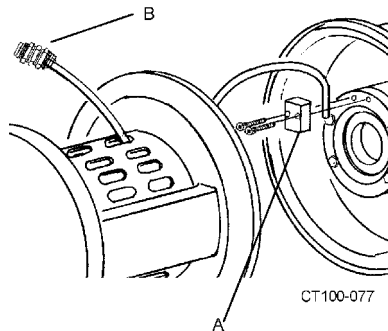

Figure 15 - Removal of the Water Cascade System

2. Pull off impeller/backplate assembly and place on a clean flat surface with impeller shaft up.

NOTE: If assembly cannot be removed from motor shaft by hand contact Waukesha Cherry-Burrell Customer Service.

3. Locate shims on motor shaft and remove.

NOTE: Motor shaft shims may fall off motor shaft or hang-up inside the deflector. **Be sure to place all shims back on motor shaft.**

CAUTION: Handle the impeller/backplate assembly with care to prevent damage to seal components.

4. Place impeller assembly **Face Down** (on impeller vanes) and remove hex head screws (Figure 14, item V) from back of seal assembly.
5. Carefully lift off seat retainer, O-ring, L-gasket, stationary seal and flush housing (Figure 14, items P, R, T, S and U).
6. Loosen (2) set screws in the spring retainer. (Figure 14, items W and H).
7. Lift off rotating seal components:

Rotary Seal (Figure 14, item L)
 O-ring (Figure 14, item M)
 Washer (Figure 14, item K)
 Spring Retainer (Figure 14, item H)
 Springs (there are six springs, 3 up and 3 down) (Figure 14, item J)
 Washer (Figure 14, item G)

8. Use backplate to slide rotary seal up the impeller shaft approximately 1-1/2 inches. (Figure 3).



Figure 16 - Moving the Rotary Seal up the Shaft

9. With the backplate resting on the impeller, push the rotary seal toward the backplate until the O-ring is free. (Figure 4).



Figure 17 - Push Rotary Seal Down Until the O-ring is Released.

10. Remove stationary seal and L-gasket from backplate. (Figure 14, items D and C).

NOTE: The stationary seal is brittle. Prying or hammering on the seal plate can shatter the seal. If the stationary seal cannot be removed by hand, place a 2-1/4 inch diameter plastic or wood rod on the impeller side of the seal and apply even pressure to dislodge the seal.

11. Inspect and replace all damaged and worn parts.

Assembly of Type 4 Seal

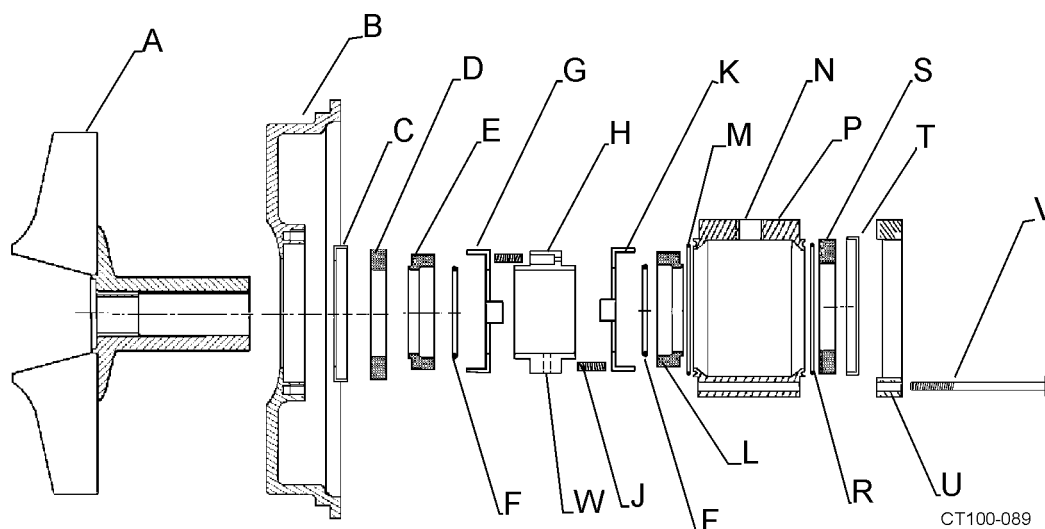

Figure 18 - Type 4 Seal Components

A. Impeller	F. O-ring	L. Rotary Seal	S. Stationary Seal
B. Backplate	G. Washer	M. O-ring	T. L-gasket
C. L-gasket	H. Spring Retainer	N. NPT Port	U. Seat Retainer
D. Stationary Seal	J. Spring	P. Flush Housing	V. Hex Head Screw (4)
E. Rotary Seal	K. Washer	R. O-ring	W. Set Screw

The following procedure covers the assembly of a pump with a Type 4 seal.

1. Clean all parts and lubricate all elastomer (Rubber-like) parts.



CAUTION: Handle the impeller/backplate assembly with care to prevent damage to seal components.

2. Install L-gasket in backplate. (Figure 18, items B and C).
3. Install L-gasket in seat retainer. (Figure 18, item T).
4. Install stationary seals (Figure 18, item S) in L-gaskets.
5. Place backplate and rotary seal onto impeller shaft.

6. Temporarily put 0.03" shims between the impeller vane and back plate to preset clearance. **Be sure to remove shims before final assembly.** (Figure 19)

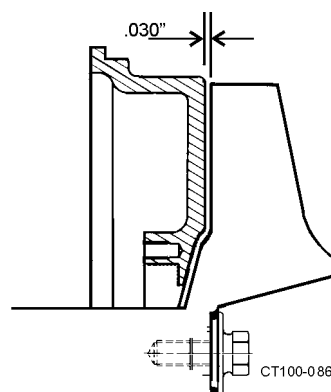

Figure 19 - Place Shims Between Impeller and Backplate

7. Place O-ring (Figure 18, item F) on shaft and use spring retainer to push O-ring into rotary seal. (Figure 20).

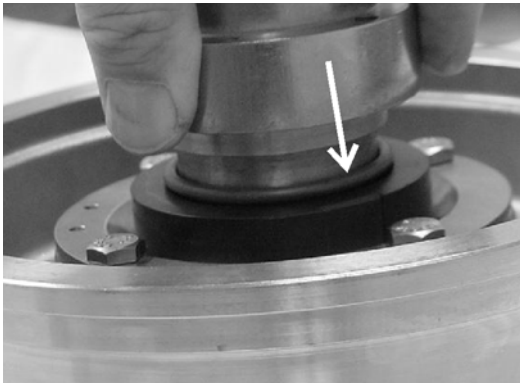

Figure 20 - Installing the O-ring using the Spring Retainer.

8. Place washer (Figure 18, item G) over rotary seal with tabs in the outside diameter notches.
9. Place three springs (Figure 18, item J) in one side of spring retainer (hold them in place with silicone sealer) and slide the spring retainer (with the springs down) onto impeller shaft against washer.
10. Place the remaining three (3) springs in the spring retainer.
11. Slide the washer and O-ring (Figure 18, items K and F) onto the shaft against the spring retainer.
12. Use the spring retainer to press the O-ring into the rotary seal.
13. Remove 1/4 NPT plug from center port on flush housing. (Figure 18, item N).
14. Install an O-ring (Figure 18, items R and M) in both ends of housing.
15. Install L-gasket in seat retainer. (Figure 18, items T and U).
16. Install stationary seal (Figure 18, item S) in L-gasket.
17. Install housing over seal assembly.
18. With flush ports facing away from the backplate place seat retainer (Figure 18, item U) on housing.

19. Tighten seat retainer in place with four (4) hex screws (Figure 18, item V).

NOTE: Be sure to tighten screws evenly until full metal to metal contact is made on backplate and seat retainer.

20. Install original shims on the motor adaptor shaft.
21. Install backplate with seal assembly and impeller on motor shaft.
22. Check impeller/backplate clearance with the backplate held firmly in position against motor adapter. Check the space between the back of the impeller and the backplate with a feeler gauge (.030 nominal) while holding the backplate tight against the bearing housing flange. (Any axial movement of the shaft should not be added to the .030 nominal clearance). (Figure 21). If needed, change this clearance by adding or removing shims. Shims (Figure 22, item A) are added on the drive shaft (Figure 22, item C) behind the impeller shaft (Figure 22, item B).

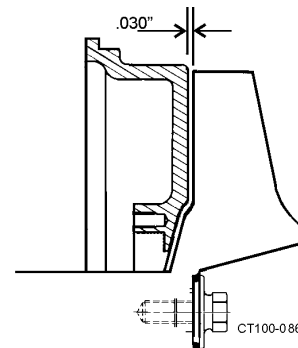

Figure 21 - Clearance Between Impeller and Backplate

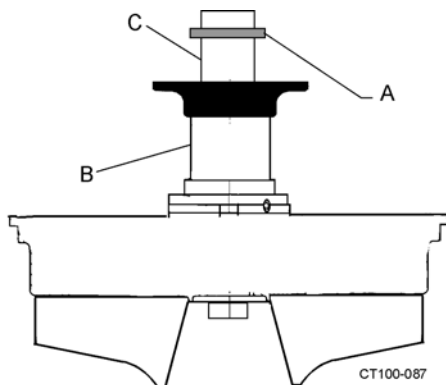

Figure 22 - Locations of Shims

23. Confirm operating clearances by clamping the casing to the bearing housing flange and rotating the shaft/impeller manually to be sure the impeller does not touch the casing or backplate.
24. Tighten set screws in the spring retainer through 1/4 NPT center port in flush housing. (Figure 18, item N).
25. Insert plug in port and tighten.
26. Remove backplate/impeller assembly and apply anti-seize or equal compound to the motor shaft and install key.
27. Install backplate/impeller assembly and lock in place using O-ring and impeller retainer bolt.
28. Install casing O-ring on backplate and clamp casing in place. (Figure 23).

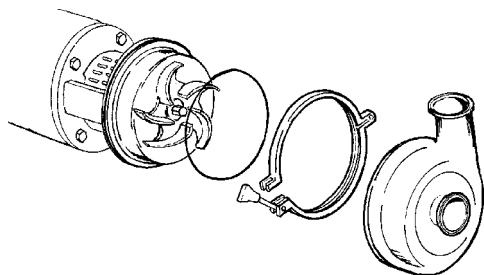

Figure 23 - Install Casing

NOTE: Rotate impeller manually to insure it does not rub on the backplate or casing.

Standard Seal Dimensions

The following seal assemblies are available with the 200 Series Pumps. These sketches provide the installed length dimension for each seal to facilitate assembly.

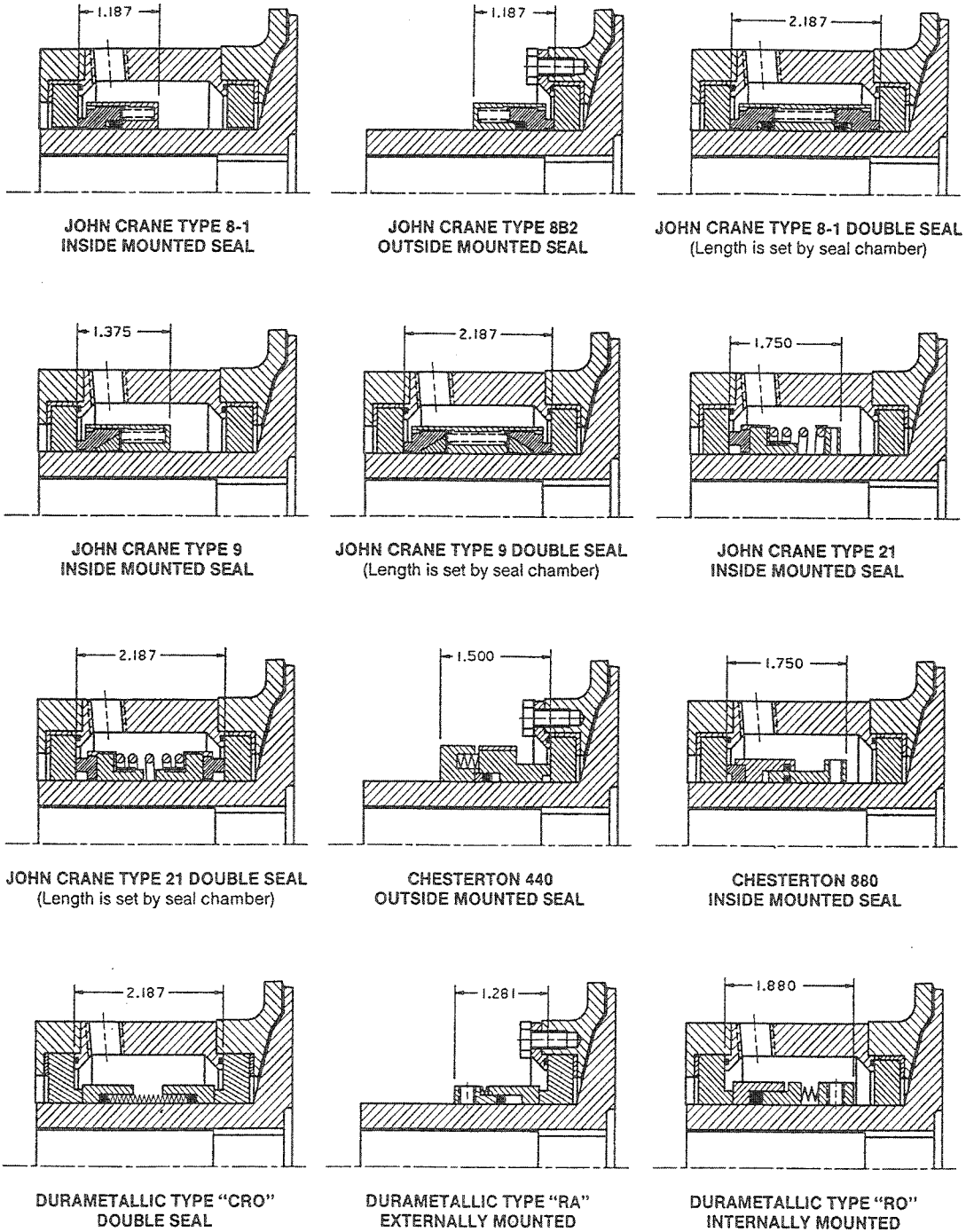

Figure 24 - Installed Seal Length (For Aid of Assembly)

Disassembly of Modular Base Mounted Pumps

Refer to see “Disassembly of Pump With a Type 1 Seal” on page 29 and “Type 4 Double Seal” on page 34 for information on disassembling the pump seal items.

1. Shut off product flow to pump and relieve any product pressure.
2. Shut off and lockout power to pump.
3. Disconnect the suction and discharge pipe fittings.
4. Remove casing clamp and casing (Figure 25, item C). Slide O-ring off of backplate.

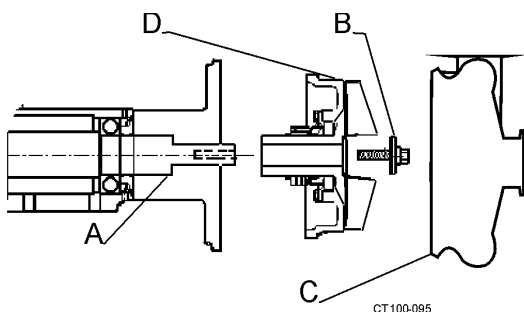

Figure 25 - Removing the Impeller Assembly

5. Remove impeller retainer bolt and shaft O-ring (Figure 25, item B).
6. Pull impeller/backplate assembly off bearing housing shaft (Figure 25, items D and A).
7. Remove the coupling cover cap screws. (Figure 26, item B).

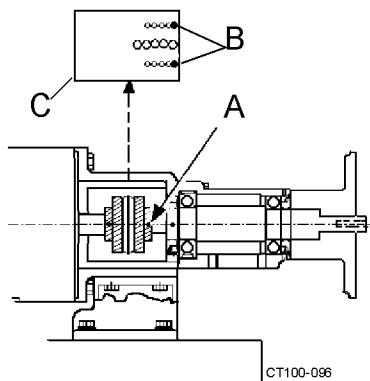

Figure 26 - Removing Coupling Covers

8. Loosen the set screws on the pump coupling. (Figure 26, item A).
9. **For Style B;** Remove bolts from adapter and stand. Remove housing and stand as a unit.
10. **For Style C;** Remove stand/housing assembly, then remove end cap. (Figure 30, item C on page 41).
11. Push the shaft and bearing assembly out of the housing from the impeller end. (Figure 27).

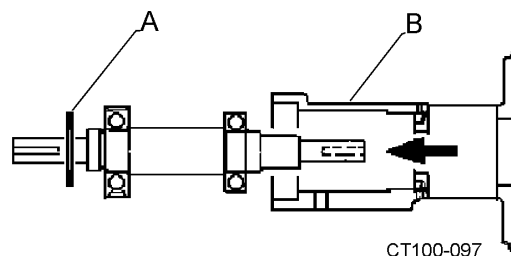

Figure 27 - Bearing Shaft Assembly Removal

12. Remove the retaining ring and press the bearings off the shaft. (Figure 27, items A and B).

Disassembling The Outer Seal Assemblies

1. Using an 1/8" hex wrench, loosen set screws (Figure 28, item A).

NOTE: The set screws are located opposite the grease fittings in the adapter or end cap.

2. Remove the impeller end of the bearing housing (Figure 28, item B).

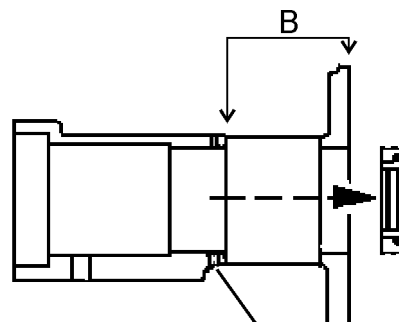

Figure 28 - Remove Set Screws

3. Remove the outer seal ring assemblies (the inner seal ring and O-rings). (Figure 28) and Figure 29.

Assembling the Outer Seal Assemblies

Reverse the above disassembly procedure with the added step of installing new O-rings in the seal rings.

NOTE: Figure 29 shows seal position at motor end. Seals at pump end face inward. Make sure to tighten set screws when installing outer seal assemblies. (Figure 30).

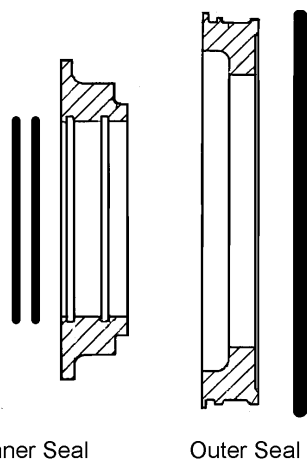

Figure 29 - Seal Configuration

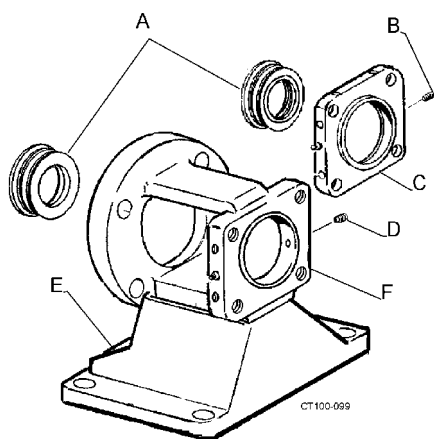

Figure 30 - Outer Seal Assemblies

- | | |
|------------------------|--------------|
| A. Outer Seal Assembly | D. Set Screw |
| B. Set Screw | E. Adaptor |
| C. End Cap | F. Stand |

NOTE: It is recommended that all rubber parts be replaced whenever a unit is dismantled for inspection or repair. Lubricate rubber parts with an approved/sanitary lubricant prior to assembly.

Pre-assembled (Cartridge) Seals

Pre-assembled (Cartridge) seals have all of the seal components mounted to a flange. They are pre-adjusted at the factory. Follow the seal manufacturer's (John Crane, A.W. Chesterton, etc.) recommendations regarding application, operation and maintenance.

NOTE: The cartridge seal comes with a set of removable lugs/spacers in place that are used to hold the assembly together until installation is final. Do not remove these lugs until installation is complete and you are told to do so in step 17 on page 44.

Disassembly of Pre-assembled (Cartridge) Seals

The following procedure covers the disassembly of pre-assembled (cartridge) seals.

1. Remove all flush connections and fittings.
2. Remove the casing clamp, casing and O-ring from the housing flange. (Figure 31).

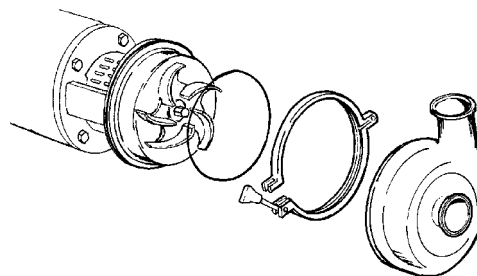

Figure 31 - Remove Casing Clamp, Casing and O-ring

- Remove the impeller retainer bolt and O-ring; then loosen the seal set screws. (Figure 32, item A).

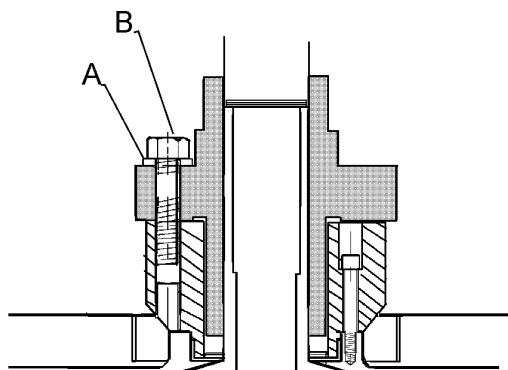

Figure 32 - Removal of Wet End

- Pull the impeller, backplate and seal off the bearing shaft as a unit. Set the assembly face down (on the impeller).

NOTE: The clearance shims that position the impeller within the casing are at the end of the impeller hub (inside the seal.) Keep shims together as a set for reassembly. (Figure 33).

- Remove cap screws (Figure 33, item B) holding the cartridge seal to the seal adapter. (Figure 33, items C and E).
- Remove seal unit from the backplate assembly.
- Pull seal from seal adapter. (Figure 33, items C and E).
- Remove seal adapter by removing socket head cap screws (Figure 33, item D) holding adapter to the back plate.

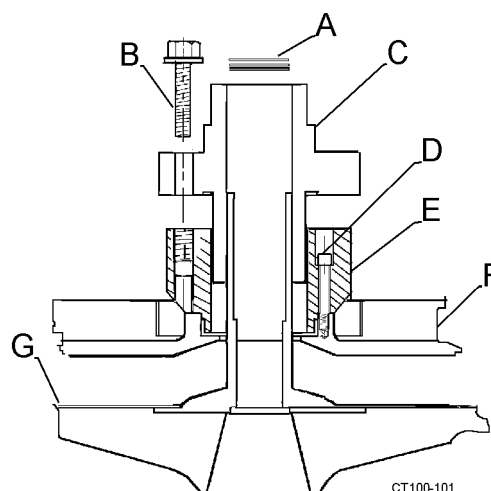

Figure 33 - Remove Seal Assembly.

- | | |
|----------------------|--------------|
| A. Shims | E. Adaptor |
| B. Cap Screw | F. Backplate |
| C. Cartridge Seal | G. Impeller |
| D. Socket Head Screw | |

Assembly of a Pump With Pre-assembled (Cartridge) Seals

The following procedure covers the disassembly of pre-assembled (cartridge) seals.

- Place shims, backplate and impeller on the shaft assembly. Hand tighten the impeller retainer bolt on the shaft.
- Check impeller/backplate clearance with the backplate held firmly in position against motor adapter. Check the space between the back of the impeller and the backplate with a feeler gauge (.030 nominal) while holding the backplate tight against the bearing housing flange. (Any axial movement of the shaft should not be added to the .030 nominal clearance). (Figure 34). If needed, change this clearance by adding or removing shims. Shims

(Figure 33, item A) are added on the drive shaft behind the impeller shaft (Figure 33, item G).

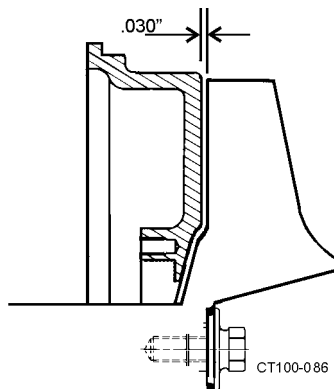

Figure 34 - Clearance Between Impeller and Backplate

3. Confirm operating clearances by clamping the casing to the bearing housing flange and rotating the shaft/impeller manually to be sure the impeller does not touch the casing or backplate.
4. When proper shim pack is confirmed remove the casing, impeller and backplate leaving the shim pack on the shaft.
5. Insert L-gasket into the backplate. (Figure 35, items B and C).
6. Insert cartridge adapter (Figure 35, item A) into the backplate (Figure 35, item C) and tighten with four socket head cap screws.(Figure 35, item D).

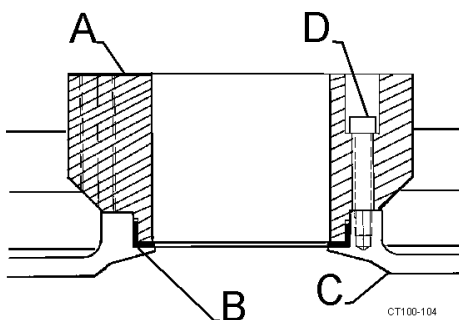

Figure 35 - Insert L-gasket and Fasten Adapter in Place

7. Install the cartridge seal unit and use retaining bolts (Figure 36, item B) and flat washers (Figure 36,

item A) to secure unit to the cartridge adapter. Make sure to not tighten the retaining bolts yet.

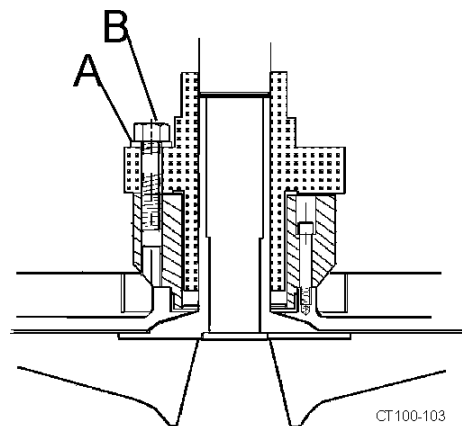

Figure 36 - Fasten Seal Unit in Place

CAUTION: Be sure the removable lugs/spacers that position the rotating part of the seal in the housing are in place at this time.

8. Apply FDA approved anti-seize compound to the shaft.
9. Install and position the seal guard. (Figure 37).

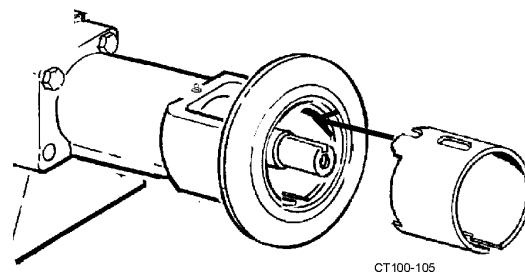

Figure 37 - Installing the Guard

10. Slide the impeller, backplate and seal unit onto the shaft.

NOTE: Be sure the flushing ports in the cartridge seal are positioned with the inlet toward the bottom and the outlet toward the top. (Figure 39, item C).

11. Install the impeller key. (Figure 38, item A).
12. Install the O-ring on the impeller retainer bolt. (Figure 38, item C).

13. Install impeller retainer bolt and tighten (Figure 38, item B).

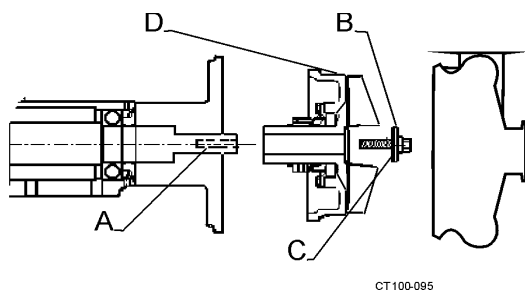

Figure 38 - Installing Impeller Assembly

14. Hold the backplate in place and tighten the cartridge seal into the cartridge adapter by tightening the cap screws (Figure 39, item E).

NOTE: The backplate and seal can be rotated to give access to the bolts through the holes in the guard.

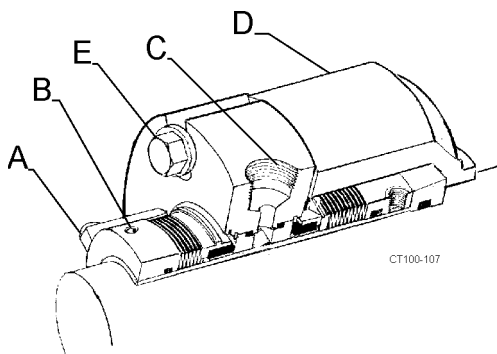

Figure 39 - Typical Cartridge Seal

Table 1: Call Outs For Figure 39

A. Lugs/Spacers	D. Seal Adaptor
B. Set Screw (2)	E. Cap Screws
C. Flush Pots	

15. Install O-ring and casing; clamp in place. (Figure 40).

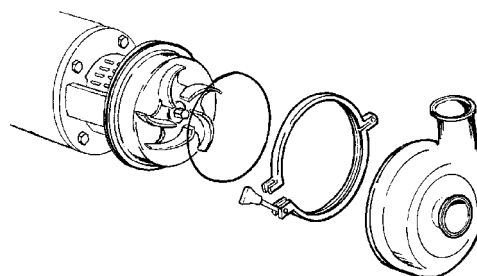

Figure 40 - Install O-ring, Casing And Clamp

16. Tighten the two set screws to the shaft. (Figure 39, item B).

17. Remove the lugs/spacers. (Figure 39, item A).

NOTE: Keep lugs/spacers to reinstall on seal cartridge if removal is ever required.

18. Connect flushing fluid and flood seal.

19. Turn the shaft manually to be sure shaft rotates without the impeller hitting or binding.

Pedestal Base Mounted Pump Housing Lubrication

Waukesha Series 200 Pedestal Pumps are lubricated with GOA Micro-Plate 555 Lithium Complex Grease. Use only NLGI grade 2 Lithium Complex thickened greases to replenish bearing grease supply. Grease fittings indicated in Figure 41.

NOTE: Mixing greases that will not mix with the above products can change the viscosity/consistency of the grease resulting in bearing damage. If there is doubt remove the bearings, clean and re-pack.

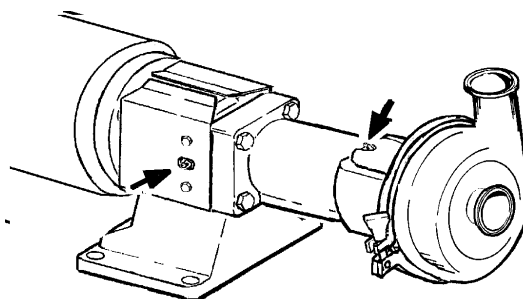

Figure 41 - Grease Fittings on the Pedestal Pump

For compatible lubricants contact Waukesha Cherry-Burrell Application Engineering at 1-800-252-5200 or 262-728-1900.

Lubrication Schedule

SIZE/RPM	HOURS
Small Bore/1750 RPM	4400
Small Bore/3500 RPM	2000
Large Bore/1750 RPM	2000
Large Bore/3500 RPM	1000

NOTE: If operating temperatures are over 158°F. (70°C.) reduce hours by half for every 27°F.(15°C.) over the operating temperature.

Pump Alignment

A flexible coupling is used to compensate for end play and small differences in alignment. The pump and drive shaft should be aligned as closely as possible.

Checking Angular Alignment

Using feeler gauges or taper gauges, adjust to get equal dimension at all points. At the same time, set space between coupling halves to manufacturer's recommended distance.

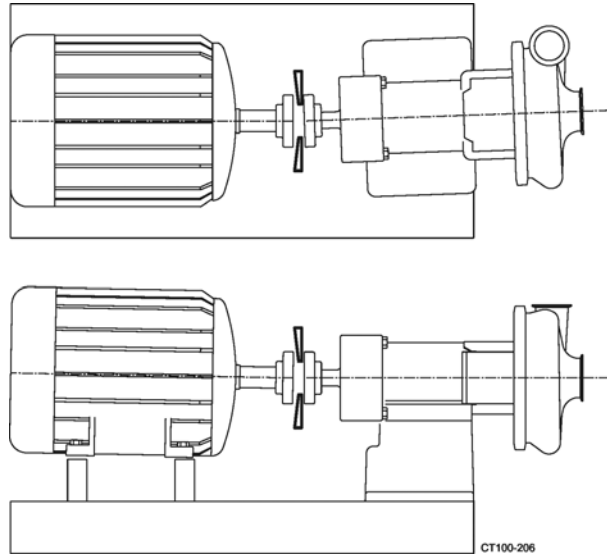

Figure 42 - Checking Angular Alignment

Checking Parallel Alignment

Using straight edges and shims, move drive and shim height as needed.

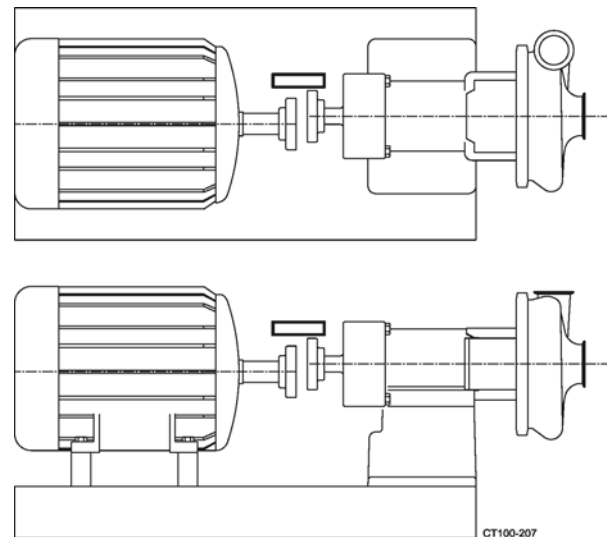

Figure 43 - Checking Parallel Alignment

Cartridge Seal Dimensions

The following pictorial list of cartridge seals is provided to assist in identifying some of the seals provided with the Model 200 centrifugal pumps. Use of these cartridges requires a cartridge seal adapter.

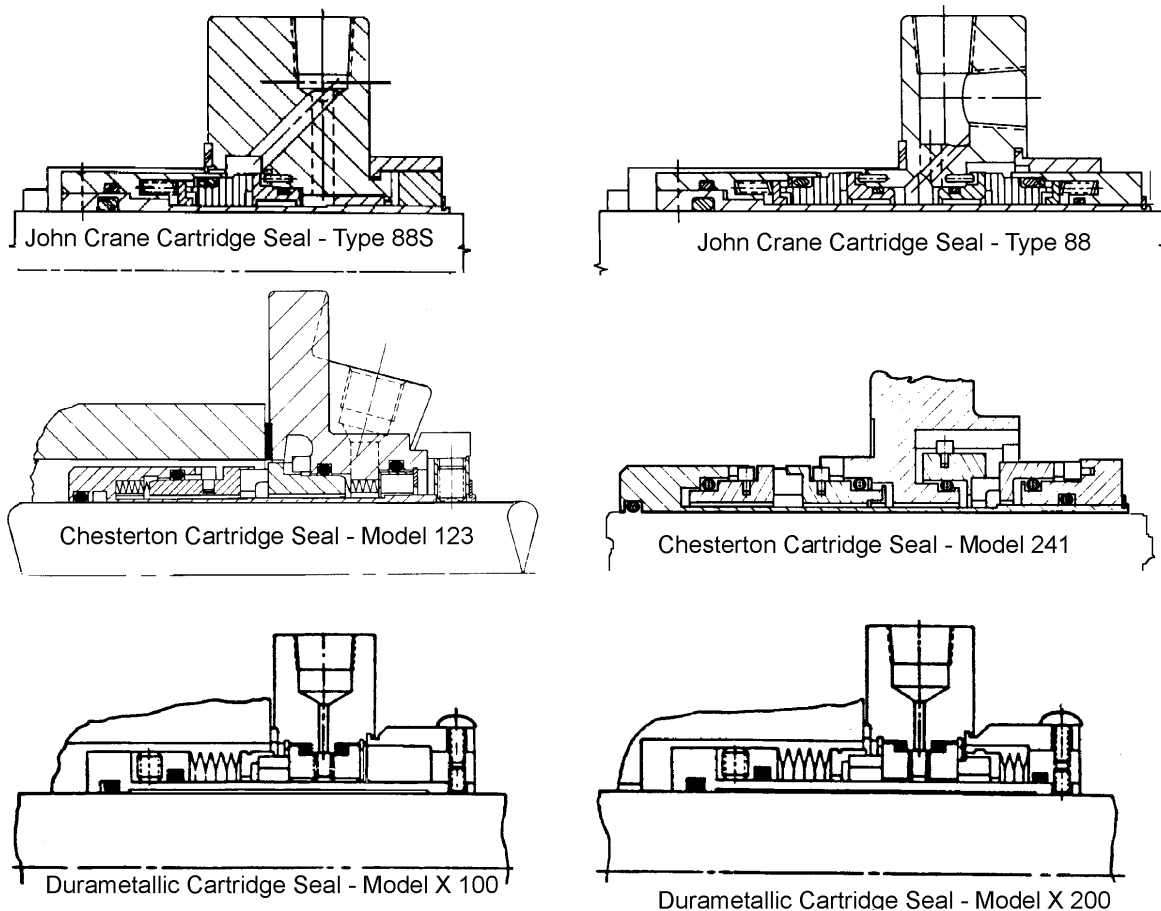
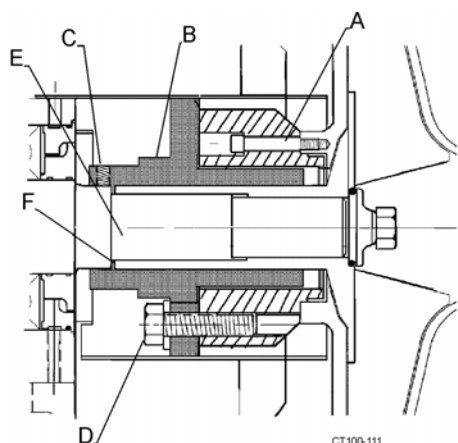

Figure 44 - Installed Cartridge Seal Length (For Aid of Assembly)



-
- A. Socket Head Cap Screw
 - B. Cartridge Seal Assembly
 - C. Set Screw (2)
 - D. Cap Screw
 - E. Bearing Shaft
 - F. Clearance Shims
-

Figure 45 - Typical Cartridge Seal Installation

Servicing the Electric Motor

See the motors manufacturer's instructions for specific service information.

General Service Information

Inspect units at regular intervals.

Keep units clean, and ventilation openings clear of dust, dirt or other debris.

Lubricate units per manufacturer's instructions and instruction plate on Unit.



CAUTION: *Do not over grease. Excessive lubrication may damage the unit.*



WARNING: *Disconnect all power sources to the unit and discharge all parts which may retain an electrical charge before attempting any maintenance or repair. Screens and covers must be maintained in place when unit is in operation.*

Motor Lubrication Instructions

Some small motors have sealed for life bearings which require no lubrication.

Greasable bearings are shipped with a high quality wide temperature range grease in the bearings.

Some motors can be greased. Refer to the motor manufacturer's instructions for more information regarding lubrication procedures and additional service procedures.

Parts Lists**Seal Kits****Basic Seal Kit - Type 1 Seal - Sanitary Pump Model**

KIT CONTAINS	QTY	MODEL				
		2045	2065*	2075	2085*	2105
CARBON SEAL	1	9-225A	9-225A	9-225A	9-225A	9-225A
SEAL O-RING	1	V70224	V70224	V70224	V70224	V70224
CASING O-RING	1	V70252	V70439	V70446	V70446	V70450
IMPELLER O-RING	1	V70214	V70220	V70220	V70220	V70220
KIT ORDER #		309-241	309-242	309-243	309-243	309-244

Complete Seal Kit - Type 1 Seal - Sanitary Pump Model

KIT CONTAINS	QTY	MODEL				
		2045	2065*	2075	2085*	2105
CARBON SEAL	1	9-225A	9-225A	9-225A	9-225A	9-225A
SEAL O-RING	1	V70224	V70224	9 10V	9 10V	V70224
CASING O-RING	1	V70252	V70439	V70446	V70446	V70450
IMPELLER O-RING	1	V70214	V70220	V70220	V70220	V70220
STATIONARY SEAL	1	23-17	23-17	23-17	23-17	23-17
L - GASKET	1	9-37	9-37	9-37	9-37	9-37
KIT ORDER #		309-245	309-246	309-247	309-247	309-248

Basic Seal Kit - Type 4 Seal - Sanitary Pump Model

KIT CONTAINS	QTY	MODEL				
		2045	2065*	2075	2085*	2105
CARBON SEAL	2	9-225A	9-225A	9-225A	9-225A	9-225A
SEAL O-RING	2	V70224	V70224	V70224	V70224	V70224
CASING O-RING	1	V70252	V70439	V70446	V70446	V70450
IMPELLER O-RING	1	V70214	V70220	V70220	V70220	V70220
HOUSING O-RING	2	V70039	V70039	V70039	V70039	V70039
KIT ORDER #		309-249	309-250	309-251	309-251	309-252

*Includes LV and HV models

Complete Seal Kit - Type 4 Seal - Sanitary Pump Model

KIT CONTAINS	QTY	MODEL				
		2045	2065*	2075	2085*	2105
CARBON SEAL	2	9-225A	9-225A	9-225A	9-225A	9-225A
SEAL O-RING	2	V70224	V70224	V70224	V70224	V70224
CASING O-RING	1	V70252	V70439	V70446	V70446	V70450
IMPELLER O-RING	1	V70214	V70220	V70220	V70220	V70220
HOUSING O-RING	2	V70039	V70039	V70039	V70039	V70039
STATIONARY SEAL	2	23-17	23-17	2317	2317	23-17
L - GASKET	2	9-37	9-37	9-37	9-37	9-37
KIT ORDER #		309-253	309-254	309-255	309-255	309-256

*Includes LV and HV models

NOTE: Metric dimensions on the outer diameter of the impeller shaft require metric seals.

NOTE: Systems using NEMA standard motors may have metric dimensions on the outer diameter of the impeller shaft to allow use of metric seal assemblies in areas where only metric seal replacements are available on short notice or where a larger system uses all metric seal materials in its operations.

To determine if you have a metric (43mm) impeller, measure the outside diameter of the impeller shaft. 1.693 inch (43mm)

For information on 43mm impellers see “Metric System Parts” on page 75 and page 50 for metric seal components.

Motor Shaft Shims

MOTOR SHAFT SHIM	PART #	MOTOR NEMA FRAME SIZE	QTY
005" THK.	35-4	254JM-326JM	AS REQUIRED
.010" THK.	35-5	254JM-326JM	AS REQUIRED
.020" THK.	35-6	254JM-326JM	AS REQUIRED
.005" THK.	35-1	142JM-215JM	AS REQUIRED
.010" THK.	35-2	142JM-215JM	AS REQUIRED
.020" THK.	35-3	142JM-215JM	AS REQUIRED

Seal Components All Pumps

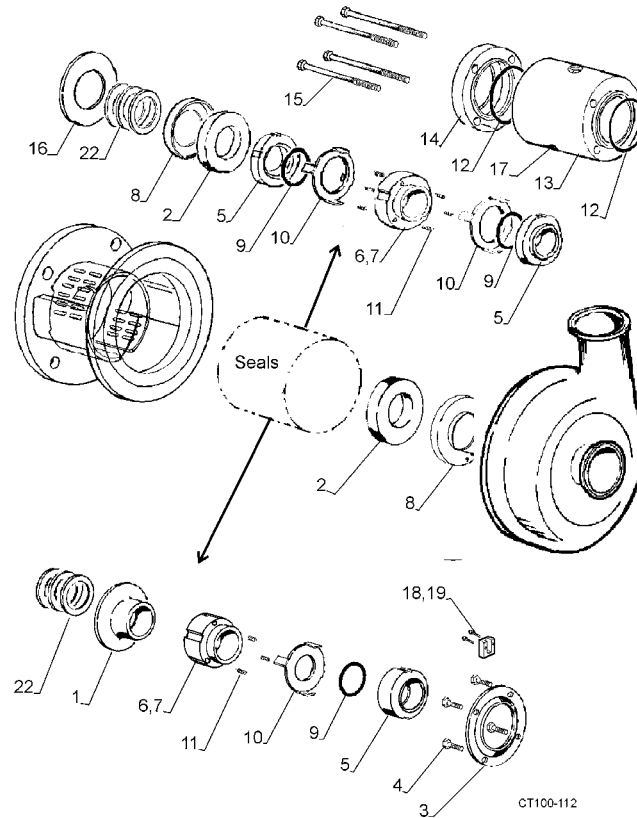

ITEM	PART #	DESCRIPTION	TYPE 1/1C SEAL QTY	TYPE 4 SEAL QTY
1	69-1	DEFLECTOR	1	-
*2	23-17	STATIONARY SEAL -PURBIDE (1.75")	1	2
	23-17A	STATIONARY SEAL -S/CARBIDE (1.75")	1	2
	23-17E	STATIONARY SEAL -CERAMIC (1.75")	1	2
	23-17F	STATIONARY SEAL -T/CARBIDE (1.75")	1	2
	23-111	STATIONARY SEAL -PURBIDE (43mm)	1	2
	23-111A	STATIONARY SEAL -S/CARBIDE (43mm)	1	2
	23-111B	STATIONARY SEAL -CERAMIC (43mm)	1	2
	23-111F	STATIONARY SEAL -T/CARBIDE (43mm)	1	2
3	23-78	SEAL RETAINER	4	-
4	30-62	1/4-20 X 1/2 BOLT (4 each)	4	-
*5	9-225A	ROTARY SEAL-CARBON (1.75")	1	2
	9-225B	ROTARY SEAL-PURBIDE (1.75")	1	2
	9-225C	ROTARY SEAL- S/CARBIDE (1.75")	1	2
	9-225F	ROTARY SEAL- T/CARBIDE (1.75")	1	2

ITEM	PART #	DESCRIPTION	TYPE 1/1C SEAL QTY	TYPE 4 SEAL QTY
	9-262A	ROTARY SEAL-CARBON (43mm)	1	2
	9-262B	ROTARY SEAL-PURBIDE (43mm)	1	2
	9-262C	ROTARY SEAL-S/CARBIDE (43mm)	1	2
	9-262F	ROTARY SEAL-T/CARBIDE (43mm)	1	2
*6	30-178	1/4-20 X 3/8 SET SCREW (2 each)	1	1
*7	23-77	SPRING RETAINER (1.75)	1	-
	23-110	SPRING RETAINER (43mm)	1	-
*8	9-37	L-GASKET-FKM	1	2
	9-37E	L-GASKET-EPDM	1	2
	9-37K	L-GASKET-FFKM	1	2
	9-37R	L-GASKET-SILICONE	1	2
*9	V70224	O-RING-FKM (1.75)	1	2
	E70224	O-RING-EPDM (1.75)	1	2
	C75224	O-RING-CHEMREZ® (1.75)	1	2
	K75224	O-RING-FFKM (1.75)	1	2
	S75224	O-RING-SILICONE (1.75)	1	2
	V70223	O-RING-FKM (43mm)	1	2
	K75223	O-RING-FFKM (43mm)	1	2
	S75223	O-RING-SILICONE (43mm)	1	2
*10	43-87	WASHER, TABBED	1	2
*11	24-65	SPRING	4	6
*12	V70039	O-RING, HOUSING	2	2
13	23-80	HOUSING, SEAL	1	1
14	23-79	RETAINER, SEAT	1	1
15	30-175	1/4-20 X 3 CAP SCREW	4	4
16	69-4	SLINGER, 142-215JM	-	1
17	78-72	1/4 N.P.T. PLUG	-	
18	134-2	BLOCK, WATER CASCADE	1	1
19	30-176	8-32 X 1/4 SOCKET HEAD	1	1
20	74-1	1/4" PLASTIC HOSE	-	
21	78-18	1/4" HOSE FITTING	-	

* Recommended spare parts.

Item #22: See "Motor Shaft Shims" on page 59.

2045 Components (Close Coupled)

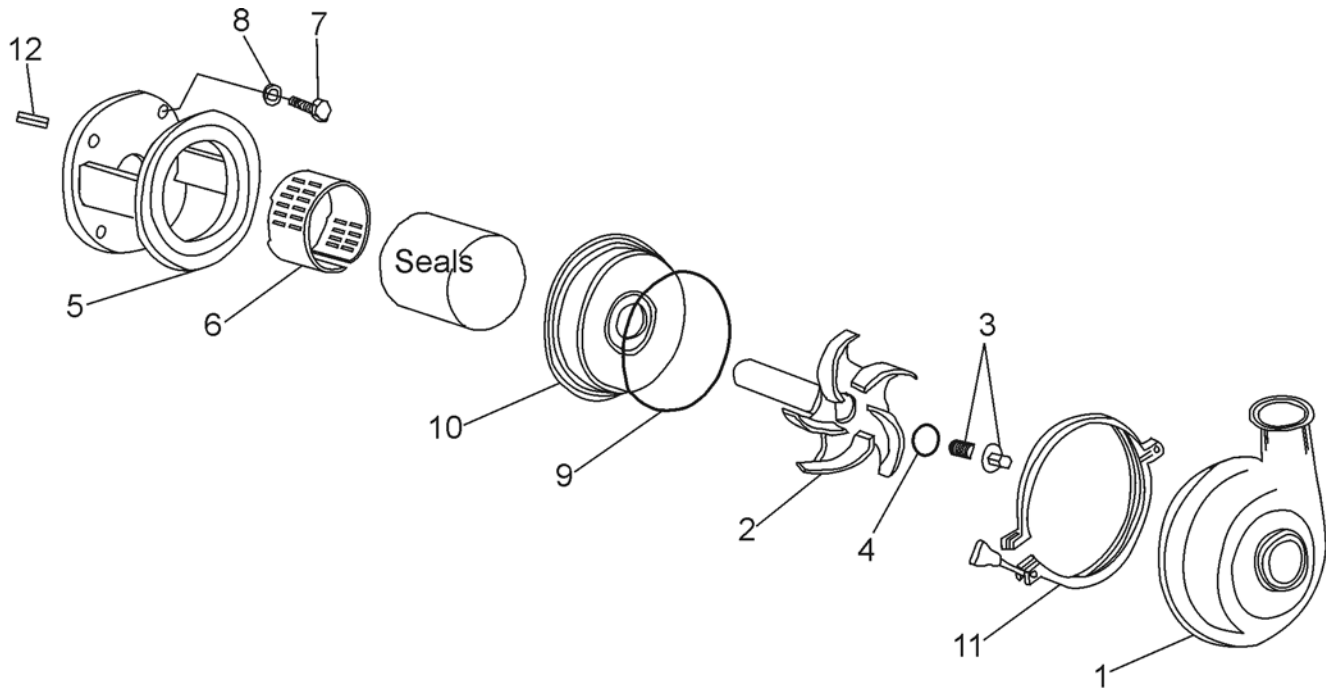

CT100-113a

ITEM	PART #	DESCRIPTION	QTY
1	301-57BX	CASING 1-1/2 X 1-1/2 BEVELED SEAT	1
	301-57EX	CASING 40mm X 40mm DIN	1
	301-57FX**	CASING 1-1/2 X 1-1/2 FLANGED	1
	301-57HX	CASING 1-1/2 X 1-1/2 FEMALE I-LINE	1
	301-57JX	CASING 1-1/2 X 1-1/2 MALE I-LINE	1
	301-57KX	CASING 1-1/2 X 1-1/2 "S" CLAMP	1
	301-57NX**	CASING 1-1/2 X I 1/2 N.P.T MALE	1
	301-57MX**	CASING 1-1/2 X 1-1/2 N.P.T. FEMALE	1
	301-57WX	CASING 1-1/2 X 1-1/2 WELD	1
	301-57QX	CASING 1-1/2 X 1-1/2 "Q" CLAMP	1
	301-58BX	CASING 2 X 1-1/2 BEVELED SEAL	1
	301-58EX	CASING 50mm X 40mm DIN	1
	301-58FX**	CASING 2 X 1-1/2 FLANGED	1
	301-58HX	CASING 2 X 1-1/2 FEMALE I-LINE	1
	301-58JX	CASING 2 X 1-1/2 MALE I-LINE	1

ITEM	PART #	DESCRIPTION	QTY
	301-58KX	CASING 2 X 1-1/2 "S" CLAMP	1
	301-58NX**	CASING 2 X 1-1/2 N.P.T. FEMALE	1
	301-58MX**	CASING 2 X 1-1/2 N.P.T. MALE	1
	301-58WX	CASING 2 X 1-1/2 WELD	1
	301-58QX	CASING 2 X 1-1/2 "Q" CLAMP	1
2	5-80X	***IMPELLER, 4-1/2 DIA.	1
3	129-773X	RETAINER, IMPELLER	1
*4	V70214	O-RING, FKM	1
	E70214	O-RING, EPDM	1
	K75214	O-RING, FFKM	1
5	2-235	ADAPTER, MOTOR	1
6	70-27	SEAL GUARD	1
7	30-50	3/8-16 X 3/4 HEX SCREW	4
8	43-28	3/8 LOCK WASHER	4
*9	V70252	O-RING, FKM	1
	E70252	O-RING EPDM	1
	S75252	O-RING SILICONE	1
	T80252	O-RING, PTFE encap.	1
	K75252	O-RING, FFKM	1
10	1-59X	BACKPLATE	1
11	119-71	CASING CLAMP	1
12	65-3	KEY -3/16" 184-215JM FRAME MOTOR	1

*Recommended spare parts.

**These casings do not meet the requirements of 3A Sanitary Standards.

*** Trimmed impellers are same part number; specify diameter to 1/16-inch (1.59mm) increments.

See "Seal Components All Pumps" on page 50 for metric seal kits.

See "Metric System Parts" on page 75 for metric parts.

2065 Components (Close Coupled)

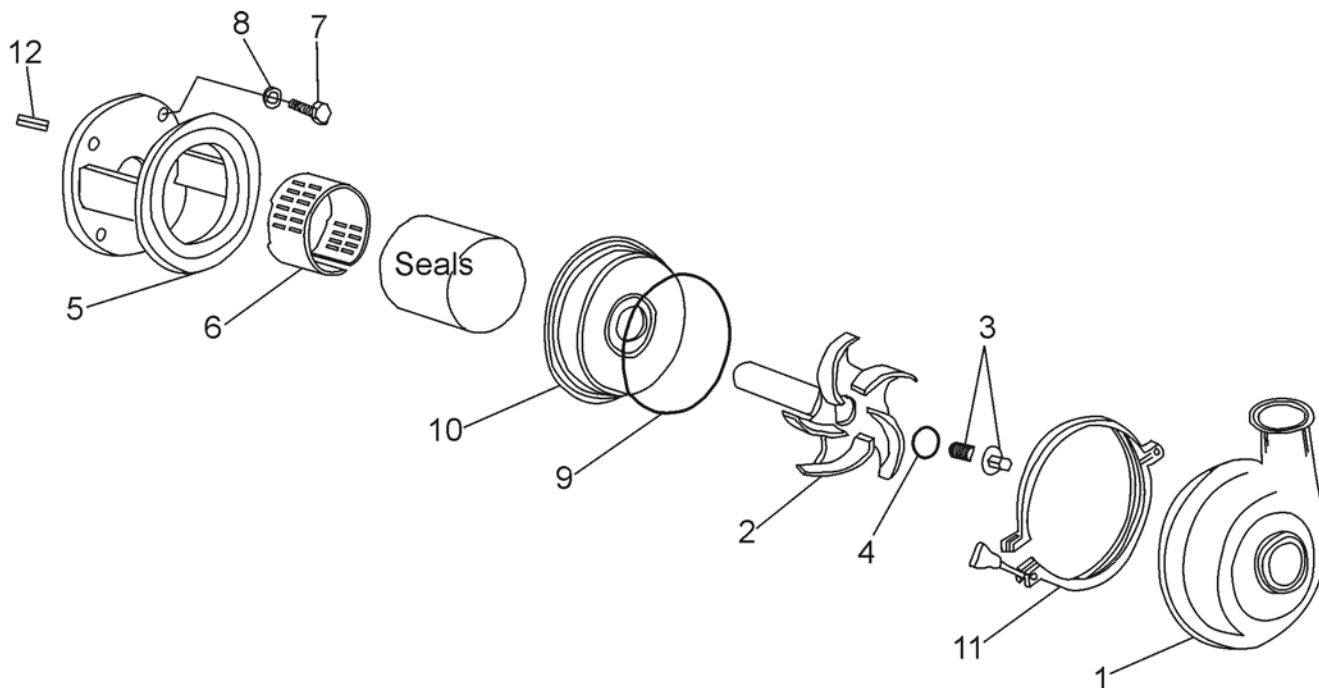

CT100-113a

ITEM	PART #	DESCRIPTION	QTY
1	301-8KX	CASING 2-1/2 X 2 "S" CLAMP (MP)	1
	301-8BX	CASING 2-1/2 X 2 BEVELED SEAT	1
	301-8HX	CASING 2-1/2 X 2 FEMALE I-LINE	1
	301-8JX	CASING 2-1/2 X 2 MALE I-LINE	1
	301-8QX	CASING 2-1/2 X 2 "Q" CLAMP	1
	301-8WX	CASING 2-1/2 X 2 WELD	1
	301-8MX**	CASING 2-1/2 X 2 N.P.T MALE	1
	301-8NX**	CASING 2-1/2 X 2 N.P.T FEMALE	1
	301-8FX**	CASING 2-1/2 X 2 150 LB FLANGE	1
2	109260	***IMPELLER 6-1/2 DIA 142-215JM MOTOR	1
	109262	***IMPELLER 6-1/2 DIA 254-326JM MOTOR	1
3	129-771X	RETAINER, IMPELLER 142-215JM MOTOR	1
	129-772X	RETAINER, IMPELLER 254-326JM MOTOR	1
*4	V70220	O-RING, FKM	1
	E70220	O-RING, EPDM	1

ITEM	PART #	DESCRIPTION	QTY
	S75220	O-RING, SILICONE	1
	K75220	O-RING, FFKM	1
5	2-168	ADAPTER, MOTOR 142-184JM FRAME	1
	2-169	ADAPTER, MOTOR 213-215JM FRAME	1
	2-170	ADAPTER MOTOR 254-256JM FRAME	1
	2-196	ADAPTER MOTOR 284-326JM FRAME	1
6	70-23	SEAL GUARD 142-215JM MOTORS	1
	70-24	SEAL GUARD 254-256JM MOTORS	1
	114508	SEAL GUARD 284-326JM MOTORS	
7	30-21	1/2-13 X 1-1/4 BOLT 213-256JM MOTORS	4
	30-30	3/8-16 X 1 BOLT 142-184JM MOTORS	4
	30-105	5/8-11 X 1-1/2 BOLT 284-326JM MOTORS	4
8	43-28	3/8 LOCK WASHER	4
	43-16	1/2 LOCK WASHER	4
	43-33	5/8 LOCK WASHER	4
*9	V70439	O-RING, FKM	1
	E70439	O-RING, EPDM	1
	S75439	O-RING, SILICONE	1
	K75439	O-RING, FFKM	1
10	1-60X	BACKPLATE	1
11	119-70	CASING CLAMP	1
12	65-3	KEY -3/16"; 142-215JM FRAME MOTOR	1
	65-4	KEY -1/4"; 254-326JM FRAME MOTOR	1

*Recommended spare parts.

**These casings do not meet the requirements of 3A Sanitary Standards.

*** Trimmed impellers are same part number; specify diameter to 1/16-inch (1.59mm) increments.

See "Seal Components All Pumps" on page 50 for metric seal its.

See "Metric System Parts" on page 75 for metric parts.

2065LV Components (Close Coupled)

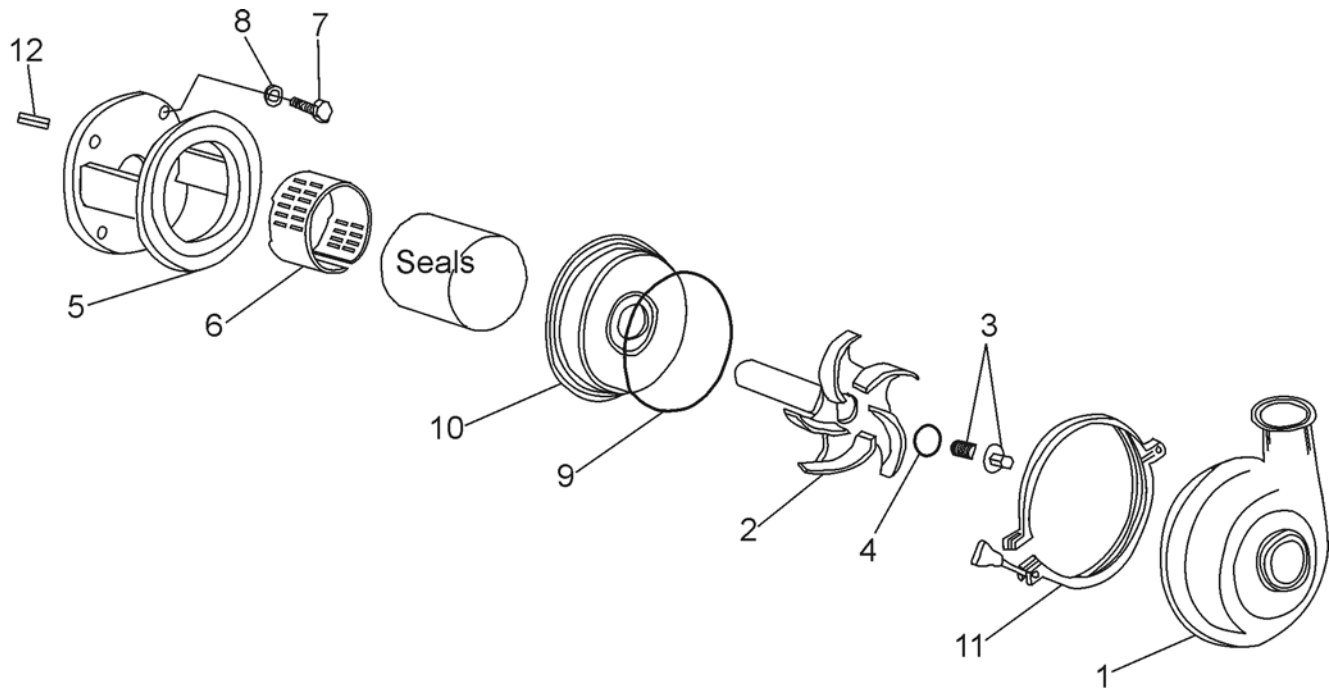

CT100-113a

ITEM	PART #	DESCRIPTION	QTY
1	301-62-X	CASING 1-1/2 X 1-1/2 "S" CLAMP	1
	301-62BX	CASING 1-1/2 X 1-1/2 BEVELED SEAT	1
	301 -62EX	CASING 40mm X 40mm DIN	1
	301-62NX**	CASING 1-1/2 X 1-1/2 N.P.T FEMALE	1
	301-62MX**	CASING 1-1/2 X 1-1/2 N.P.T MALE	1
	301-62FX**	CASING 1-1/2 X 1-1/2 FLANGE	1
	301-62WX	CASING 1-1/2 X 1-1/2 WELD	1
	301-62HX	CASING 1-1/2 X 1-1/2 FEMALE I-LINE	1
	301-62JX	CASING 1-1/2 X 1-1/2 MALE I-LINE	1
	301 -62QX	CASING 1-1/2 X 1-1/2 "Q" CLAMP	1
	301-63KX	CASING 2 X 1-1/2 "S" CLAMP	1
	301-63EX	CASING 50mm X 40mm DIN	1
	301 -63BX	CASING 2 X 1-1/2 BEVELED SEAT	1
	301-63NX	CASING 2 X 1-1/2 N.P.T FEMALE	1
	301-63MX	CASING 2 X 1-1/2 N.P.T MALE	1

ITEM	PART #	DESCRIPTION	QTY
	301-63FX	CASING 2 X 1-1/2 FLANGE	1
	301-63WX	CASING 2 X 1-1/2 WELD	1
	301-63HX	CASING 2 X 1-1/2 FEMALE I-LINE	1
	301-63JX	CASING 2 X 1-1/2 MALE I-LINE	1
	301-63QX	CASING 2X 1 1/2 "Q" CLAMP	1
	301-64KX	CASING 1-1/2 X 1-1/2 "S" CLAMP (MP)	1
	301-64BX	CASING 2-1/2 X 1-1/2 BEVELED SEAT	1
	301-64EX	CASING 65mm X 40mm DIN	1
	301-64NX**	CASING 2-1/2 X 1-1/2 N.P.T FEMALE	1
	301-64MX**	CASING 2-1/2 X 1-1/2 N.P.T MALE	1
	301-64FX**	CASING 2-1/2 X 1 1/2 FLANGE	1
	301-64WX	CASING 2-1/2 X 1-1/2 WELD	1
	301-64HX	CASING 2-1/2 X 1-1/2 FEMALE I-LINE	1
	301-64JX	CASING 2-1/2 X 1-1/2 MALE I-LINE	1
	301-64QX	CASING 2-1/2 X 1-1/2 "Q" CLAMP	1
2	109256	**IMPELLER 6-1/2 DIA 142-215JM MOTOR	1
	109258	**IMPELLER 6-1/2 DIA 254-326JM MOTOR	1

NOTE: Refer to "2065 Components (Close Coupled)" on page 54 for items 3-12.

**These casings do not meet the requirements of 3A Sanitary Standards.

*** Trimmed impellers are same part number; specify diameter to 1/16-inch (1.59mm) increments.

See "Seal Components All Pumps" on page 50 for metric seal kits.

See "Metric System Parts" on page 75 for metric parts.

2065HV Components (Close Coupled)

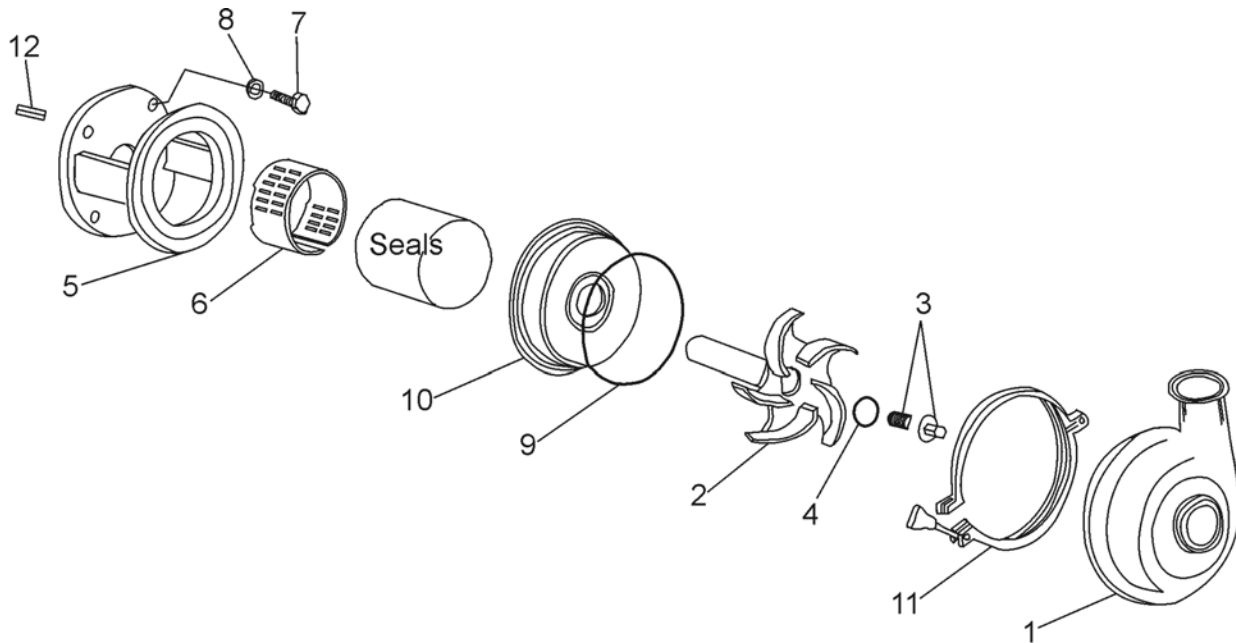

CT100-113a

ITEM	PART #	DESCRIPTION	QTY
1	301-17BX**	CASING 3 X 2 BEVELED SEAT	1
	301-17EX**	CASING 80mm X 50mm DIN	1
	301-17FX**	CASING 3 X 2 FLANGED	1
	301-17HX**	CASING 3 X 2 FEMALE I-LINE	1
	301-17JX**	CASING 3 X 2 MALE I-LINE	1
	301-17KX**	CASING 3 X 2 "S" CLAMP	1
	301-17NX**	CASING 3 X 2 N.P.T. FEMALE	1
	301-17MX**	CASING 3 X 2 N.P.T MALE	1
	301-17QX**	CASING 3 X 2 "Q" CLAMP	1
2	109264	***IMPELLER 6-1/2 DIA 142-215JM MOTOR	1
	109266	***IMPELLER 6-1/2 DIA 254-326JM MOTOR	1
3	129-771X	RETAINER, IMPELLER 142-215JM MOTOR	1
	129-772X	RETAINER, IMPELLER 254-326JM MOTOR	1
*4	V70220	O-RING, FKM	1
	E70220	O-RING, EPDM	1
	S75220	O-RING, SILICONE	1
	K75220	O-RING, FFKM	1

ITEM	PART #	DESCRIPTION	QTY
5	2-168	ADAPTER, MOTOR 142-184JM FRAME	1
	2-169	ADAPTER, MOTOR 213-215JM FRAME	1
	2-170	ADAPTER MOTOR 254-256JM FRAME	1
	2-196	ADAPTER MOTOR 284-326JM FRAME	1
6	70-23	SEAL GUARD 142-215 MOTORS	1
	70-24	SEAL GUARD 254-256 MOTORS	1
	114508	SEAL GUARD 284-326 MOTORS	1
7	30-21	1/2-13 X 1-1/4 BOLT 213-256JM MOTORS	4
	30-30	3/8-16 X 1 BOLT 142-184JM MOTORS	4
	30-105	5/8-11 X 1-1/2 BOLT 284-326JM MOTORS	4
8	43-28	3/8 LOCK WASHER	4
	43-16	1/2 LOCK WASHER	4
	43-33	5/8 LOCK WASHER	4
*9	V70439	O-RING, FKM	1
	E70439	O-RING, EPDM	1
	S75439	O-RING, SILICONE	1
	K75439	O-RING, FFKM	1
10	1-60X	BACKPLATE	1
11	119-70	CASING CLAMP	1
12	65-3	KEY -3/16"; 142-215JM FRAME MOTOR	1
	65-4	KEY -1/4"; 254-326JM FRAME MOTOR	1

*Recommended spare parts.

**These casings do not meet the requirements of 3A Sanitary Standards.

*** Trimmed impellers are same part number; specify diameter to 1/16-inch (1.59mm) increments.

See "Seal Components All Pumps" on page 50 for metric seal kits.

See "Metric System Parts" on page 75 for metric parts.

2075 Components (Close Coupled)

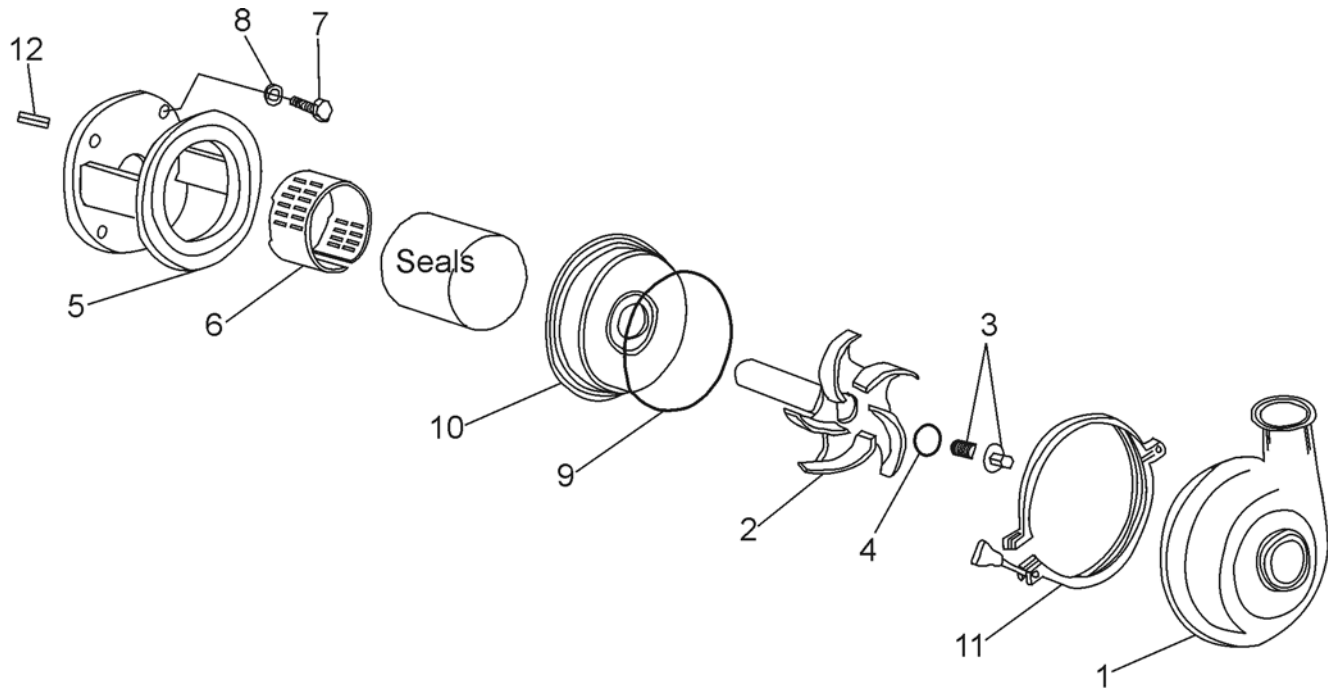

CT100-113a

ITEM	PART #	DESCRIPTION	QTY
1	CENTPT00747	CASING 50mm X 40mm DIN	1
	CENTPT00669	CASING 3 X 1-1/2 "S" LINE	1
	CENTPT00670	CASING 3 X 1-1/2 BEVEL	1
	CENTPT00671	CASING 3 X 1-1/2 FEMALE "I" LINE	1
	CENTPT00672	CASING 3 X 1-1/2 MALE "I" LINE	1
	CENTPT00673	CASING 3 X 1-1/2 "Q" LINE	1
	CENTPT00674	CASING 3 X 1-1/2 WELD	1
	CENTPT00675	CASING 3 X 1-1/2 N.P.T MALE	1
	CENTPT00676	CASING 3 X 1-1/2 N.P.T FEMALE	1
	CENTPT00677	CASING 3 X 1-1/2 FLANGE 150#	1
2	109723	***IMPELLER 8.7 DIA. 142-215JM MOTOR	1
	109741	***IMPELLER 8.7 DIA. 254-326JM MOTOR	1
3	129-771X	RETAINER, IMPELLER 143-215JM MOTOR	1
	129-772X	RETAINER, IMPELLER 254JM AND LARGER MOTOR	1
*4	V70220	O-RING, FKM	1
	E70220	O-RING, EPDM	1

ITEM	PART #	DESCRIPTION	QTY
	S70220	O-RING, SILICONE	1
	K75220	O-RING, FFKM	1
5	2-171	ADAPTER, MOTOR 142-184JM FRAME	1
	2-172	ADAPTER, MOTOR 213-215JM FRAME	1
	2-173	ADAPTER, MOTOR 254-256JM FRAME	1
	2-174	ADAPTER, MOTOR 284-326JM MOTOR	1
6	70-23	SEAL GUARD 142-215JM MOTOR	1
	70-24	SEAL GUARD 254-256JM MOTOR	1
	114508	SEAL GUARD 284-326JM MOTOR	1
7	30-30	3/8-16 X 1 BOLT 142-184JM MOTOR	4
	30-36X	1/2-13 X 1 1/4 BOLT 213-256JM MOTOR	4
	30-105	5/8-11 X 1-1/2 BOLT 284-326JM MOTOR	4
8	43-28	3/8 LOCK WASHER	4
	43-16	1/2 LOCK WASHER	4
	43-33	5/8 LOCK WASHER	4
*9	V70446	O-RING, FKM	1
	E70446	O-RING, EPDM	1
	S75446	O-RING, SILICONE	1
	K75446	O-RING, FFKM	1
10	1-61X	BACKPLATE	1
11	119-69	CASING CLAMP	1
12	65-3	KEY -3/16"; 142-215JM FRAME MOTOR	1
	65-4	KEY -1/4"; 254-326JM FRAME MOTOR	1

*Recommended spare parts.

**These casings do not meet the requirements of 3A Sanitary Standards.

*** Trimmed impellers are same part number; specify diameter to 1/16-inch (1.59mm) increments.

See "Seal Components All Pumps" on page 50 for metric seal kits.

See "Metric System Parts" on page 75 for metric parts.

2085 Components (Close Coupled)

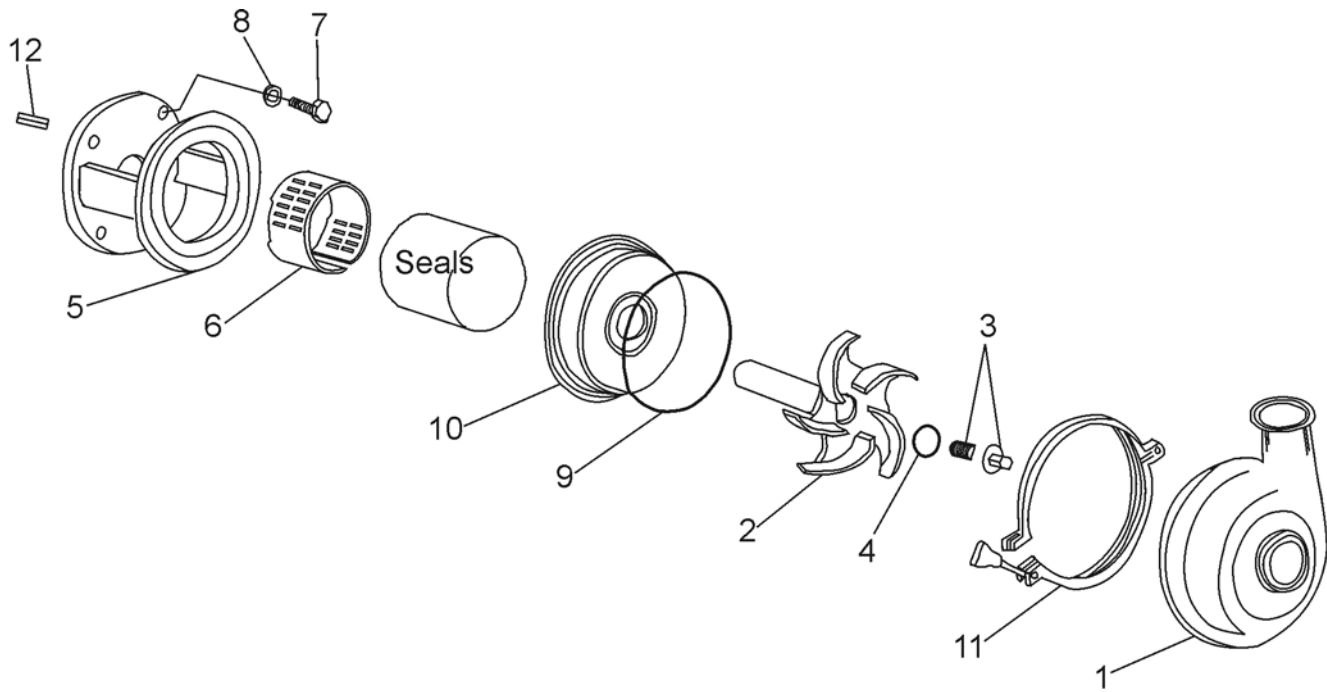

CT100-113a

ITEM	PART #	DESCRIPTION	QTY
1	301-5BX	CASING 3 X 2-1/2 BEVELED SEAT	1
	301-5EX	CASING 80mm X 65mm DIN	1
	301-5FX**	CASING 3 X 2-1/2 FLANGE	1
	301-5HX	CASING 3 X 2-1/2 MALE "I" LINE	1
	301-5JX	CASING 3X 2-1/2 FEMALE "I" LINE	1
	301-5KX	CASING 3X2-1/2 CLAMP	1
	301-5NX**	CASING 3 X 2-1/2 N.P.T FEMALE	1
	301-5MX**	CASING 3X2-1/2 N.P.T MALE	1
	301 -5WX	CASING 3 X 2-1/2 WELD	1
	301-5QX	CASING 3 X 2-1/2 "Q" CLAMP	1
	301-7BX	CASING 4 X 2-1/2 BEVELED SEAT	1
	301-7EX	CASING 100mm X 65mm DIN	1
	301-7FX**	CASING 4 X 2-1/2 FLANGE	1
	301-7HX	CASING 4 X 2-1/2 MALE "I" LINE	1
	301-7JX	CASING 4 X 2-1/2 FEMALE "I" LINE	1
	301-7KX	CASING 4 X 2-1/2 "S" CLAMP	1
	301-7NX**	CASING 4 X 2-1/2 N.P.T. FEMALE	1
	301-7MX**	CASING 4 X 2-1/2 N.P.T. MALE	1
	301 -7WX	CASING 4 X 2-1/2 WELD	1
	301-7QX	CASING 4 X 2-1/2 "Q" CLAMP	1

ITEM	PART #	DESCRIPTION	QTY
2	109248	***IMPELLER 8.7 DIA. 142-215JM MOTOR	1
	109249	***IMPELLER 8.7 DIA. 254-326JM MOTOR	1
3	129-771X	RETAINER, IMPELLER 142-215JM MOTOR	1
	129-772X	RETAINER, IMPELLER 254-326JM MOTOR	1
*4	V70220	O-RING, FKM	1
	E70220	O-RING, EPDM	1
	S70220	O-RING, SILICONE	1
	K75220	O-RING, FFKM	1
5	2-171	ADAPTER, MOTOR 142-184JM FRAME	1
	2-172	ADAPTER, MOTOR 213-215JM FRAME	1
	2-173	ADAPTER, MOTOR 254-256JM FRAME	1
	2-174	ADAPTER, MOTOR 284-326JM MOTOR	1
6	70-23	SEAL GUARD 142-215JM MOTOR	1
	70-24	SEAL GUARD 254-256JM MOTOR	1
	114508	SEAL GUARD 284-326JM MOTOR	1
7	30-30	3/8-16 X 1 BOLT 142-184JM MOTOR	4
	30-36X	1/2-13 X 1 1/4 BOLT 213-256JM MOTOR	4
	30-105	5/8-11 X 1-1/2 BOLT 284-326JM MOTOR	4
8	43-28	3/8 LOCK WASHER	4
	43-16	1/2 LOCK WASHER	4
	43-33	5/8 LOCK WASHER	4
*9	V70446	O-RING, FKM	1
	E70446	O-RING, EPDM	1
	S75446	O-RING, SILICONE	1
	K75446	O-RING, FFKM	1
10	1-61X	BACKPLATE	1
11	119-69	CASING CLAMP	1
12	65-3	KEY -3/16"; 142-215JM FRAME MOTOR	1
	65-4	KEY -1/4"; 254-326JM FRAME MOTOR	1

*Recommended spare parts

**These casings do not meet the requirements of 3A Sanitary Standards.

*** Trimmed impellers are same part number; specify diameter to 1/16-inch (1.59mm) increments.

See "Seal Components All Pumps" on page 50 for metric seal kits.

See "Metric System Parts" on page 75 for metric parts.

2085LV Components (Close Coupled)

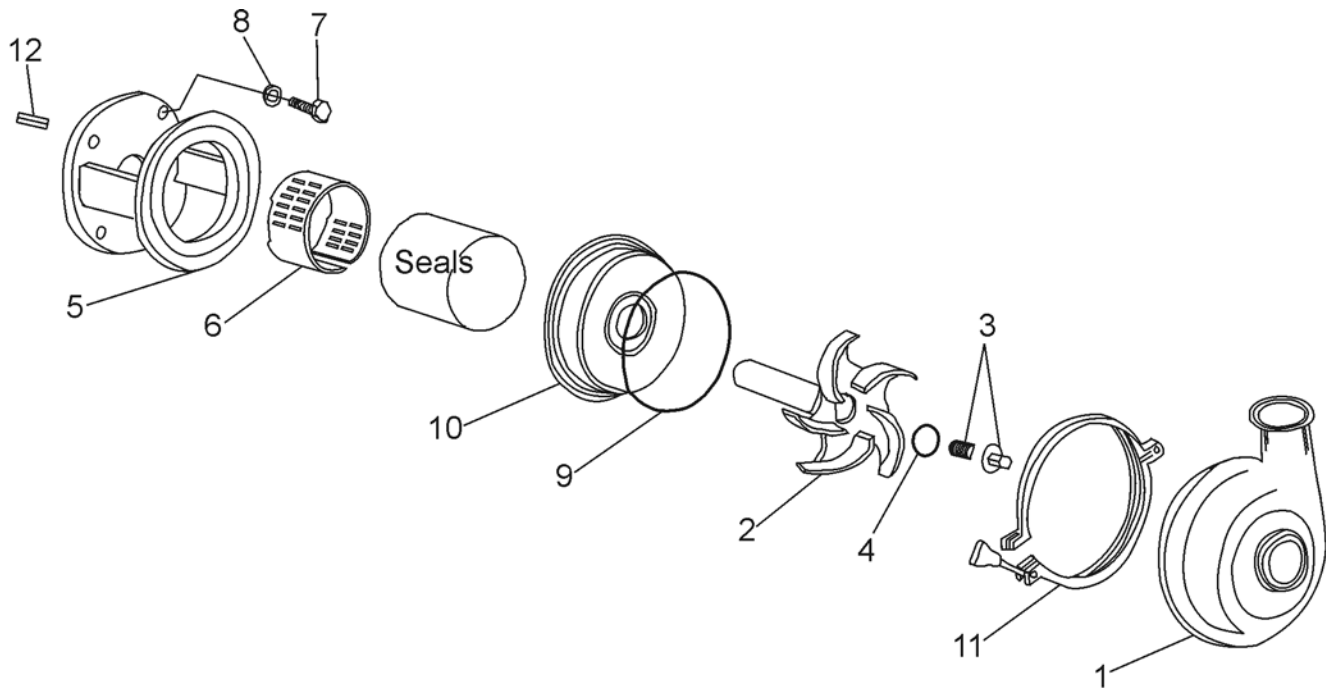

CT100-113a

ITEM	PART #	DESCRIPTION	QTY
1	301-18EX	CASING 50mm X 40mm DIN	1
	301-18FX**	CASING 2 X 1-1/2 FLANGE	1
	301-1 8HX	CASING 2 X 1-1/2 FEMALE " I" LINE	1
	301-18JX	CASING 2 X 1-1/2 MALE "I" LINE	1
	301-18KX	CASING 2X 1-1/2 "S" CLAMP	1
	301 -18NX**	CASING 2 X 1-1/2 N.P.T FEMALE	1
	301-18MX**	CASING 2 X 1-1/2 N.P.T MALE	1
	301-18WX	CASING 2 X 1-1/2 WELD	1
	301-18QX	CASING 2 X 1-1/2 "Q" CLAMP	1
2	109723	***IMPELLER 8.7 DIA. 142-215JM MOTOR	1
	109741	***IMPELLER 8.7 DIA. 254-326JM MOTOR	1
3	129-771X	RETAINER, IMPELLER 142-215JM MOTOR	1
	129-772X	RETAINER, IMPELLER 254-326JM MOTOR	1
*4	V70220	O-RING, FKM	1
	E70220	O-RING, EPDM	1

ITEM	PART #	DESCRIPTION	QTY
	S70220	O-RING, SILICONE	1
	K75220	O-RING, FFKM	1
5	2-171	ADAPTER, MOTOR 142-184JM FRAME	1
	2-172	ADAPTER, MOTOR 213-215JM FRAME	1
	2-173	ADAPTER, MOTOR 254-256JM FRAME	1
	2-174	ADAPTER, MOTOR 284-326JM MOTOR	1
6	70-23	SEAL GUARD 142-215JM MOTOR	1
	70-24	SEAL GUARD 254-256JM MOTOR	1
	114508	SEAL GUARD 284-326JM MOTOR	1
7	30-30	3/8-16 X 1 BOLT 142-184JM MOTOR	4
	30-36X	1/2-13 X 1 1/4 BOLT 213-256JM MOTOR	4
	30-105	5/8-11 X 1-1/2 BOLT 284-326JM MOTOR	4
8	43-28	3/8 LOCK WASHER	4
	43-16	1/2 LOCK WASHER	4
	43-33	5/8 LOCK WASHER	4
*9	V70446	O-RING, FKM	1
	E70446	O-RING, EPDM	1
	S75446	O-RING, SILICONE	1
	K75446	O-RING, FFKM	1
10	1-61X	BACKPLATE	1
11	119-69	CASING CLAMP	1
12	65-3	KEY -3/16"; 142-215JM FRAME MOTOR	1
	65-4	KEY -1/4"; 254-326JM FRAME MOTOR	1

*Recommended spare parts.

**These casings do not meet the requirements of 3A Sanitary Standards.

*** Trimmed impellers are same part number; specify diameter to 1/16-inch (1.59mm) increments.

See "Seal Components All Pumps" on page 50 for metric seal kits.

See "Metric System Parts" on page 75 for metric parts.

2105 Components (Close Coupled)

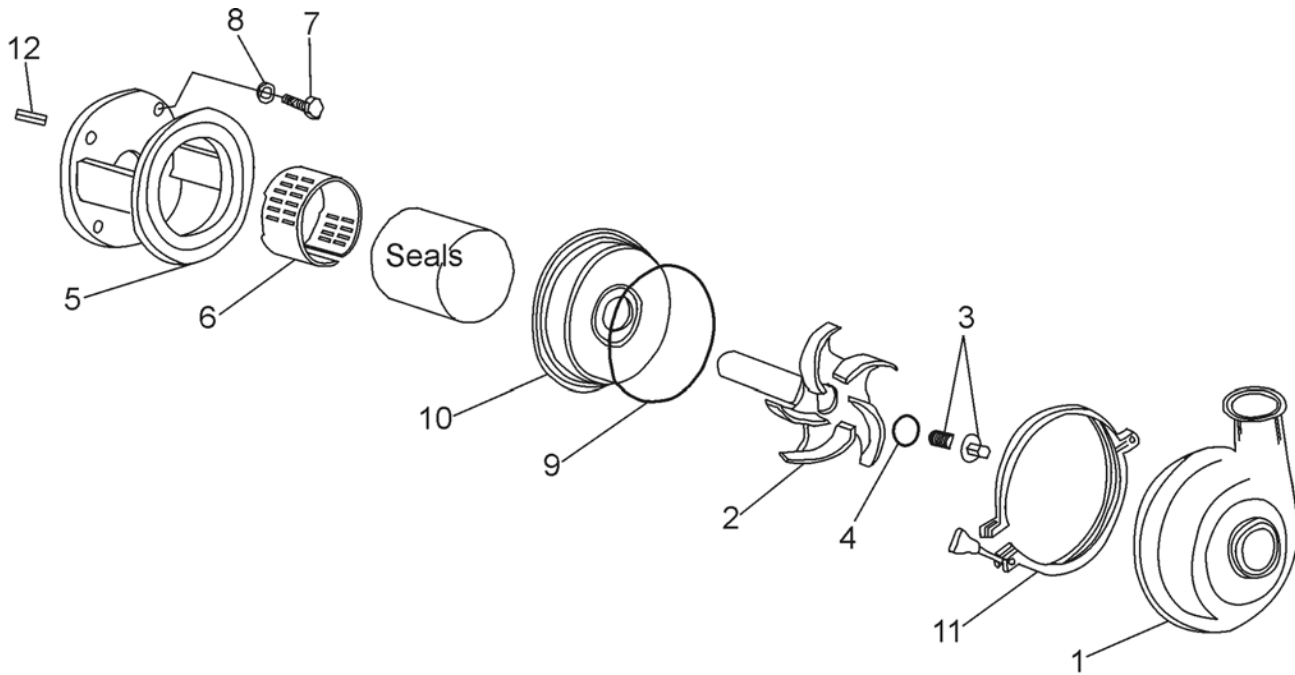

CT100-113a

ITEM	PART #	DESCRIPTION	QTY
1	301-28BX	CASING 4 X 4 BEVELED SEAT	1
	301-28EX	CASING 100mm X 100mm DIN	1
	301-28FX**	CASING 4 X 4 FLANGE	1
	301-28HX	CASING 4 X 4 FEMALE I-LINE	1
	301-28JX	CASING 4 X 4 MALE I-LINE	1
	301-28KX	CASING 4 X 4 "S" CLAMP	1
	301-28NX**	CASING 4 X 4 N.P.T FEMALE	1
	301-28MX**	CASING 4 X 4 N.P.T. MALE	1
	301-28WX	CASING 4 X 4 WELD	1
	301-28QX	CASING 4 X 4 "Q" CLAMP	1
	301-56EX	CASING 150mm X 100mm DIN	1
	301-56BX	CASING 6 X 4 BEVELED SEAT	1
	301-56FX**	CASING 6 X 4 150 LB FLANGE	1
	301-56NX**	CASING 6 X 4 NPT; FEMALE	1
	301-56MX**	CASING 6 X 4 NPT; MALE	1
	301-56HX	CASING 6 X 4 FEMALE I-LINE	1
	301-56JX	CASING 6X 4 MALE I-LINE	1
	301-56KX	CASING 6 X 4 "S" CLAMP	1
	301-56WX	CASING 6 X 4 WELD	1

ITEM	PART #	DESCRIPTION	QTY
2	5-72X	***IMPELLER 10-1/2 DIA 184-215JM MOTORS	1
	5-70X	***IMPELLER 10-1/2 DIA 254-326JM MOTOR	1
3	129-771X	RETAINER, IMPELLER 142-215JM MOTORS	1
	129-772X	RETAINER, IMPELLER 245-326JM MOTOR	1
*4	V70220	O-RING, FKM	1
	E70220	O-RING, EPDM	1
	S75220	O-RING, SILICONE	1
	K75220	O-RING, FFKM	1
5	2-233	ADAPTER, MOTOR 142-184JM FRAME	1
	2-230	ADAPTER, MOTOR 213-215JM FRAME	1
	2-231	ADAPTER, MOTOR 254-256JM FRAME	1
	2-232	ADAPTER, MOTOR 284-326JM FRAME	1
6	70-23	SEAL GUARD 142-215JM MOTOR	1
	70-24	SEAL GUARD 254-256JM MOTOR	1
	70-25	SEAL GUARD 284-326JM MOTOR	1
7	30-30	3/8-16 X 1 BOLT 142-184JM MOTOR	4
	30-36X	1/2-13 X 1-1/4 BOLT 213-256JM MOTOR	4
	30-105	5/8-11 X 1-1/2 BOLT 284-326JM MOTOR	4
8	43-28	3/8 LOCK WASHER	4
	43-16	1/2 LOCK WASHER	4
	43-33	5/8 LOCK WASH ER	4
*9	E70450	O-RING, EPDM	1
	S75450	O-RING, SILICONE	1
	K75450	O-RING, FFKM	1
10	1-29X	BACKPLATE	1
11	119-223	CASING CLAMP	1
12	65-3	KEY -3/16"; 142-215JM FRAME MOTOR	1
	65-4	KEY -1/4"; 254-326JM FRAME MOTOR	1

*Recommended spare parts.

**These casings do not meet the requirements of 3A Sanitary Standards.

*** Trimmed impellers are same part number; specify diameter to 1/16-inch (1.59mm) increments.

See "Seal Components All Pumps" on page 50 for metric seal kits.

See "Metric System Parts" on page 75 for metric parts.

Motor Mounts

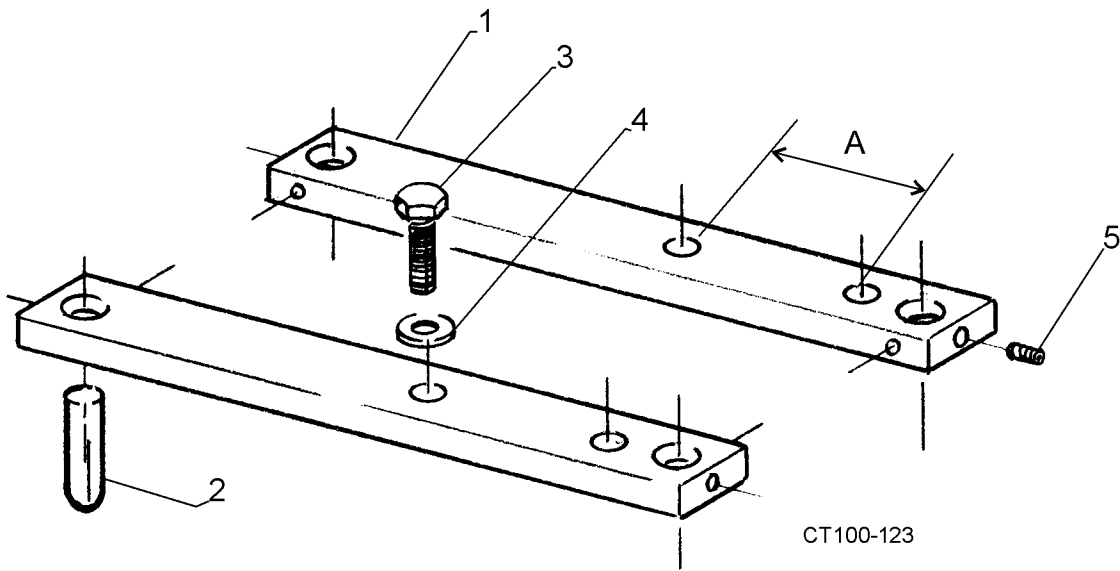

FRAME	COMPLETE MOUNTING KIT #	ITEM 1 PART #	ITEM 2 PART #	ITEM 3 PART #	ITEM 4 PART #	ITEM 5 PART #	A IN INCHES
56	355-1	55-1	4-1	30-30	43-28	30-22	3
143	355-2	55-2	4-1	30-30	43-28	30-22	4
145	355-3	55-3	4-1	30-30	43-28	30-22	5
182	355-4	55-4	4-1	30-30	43-28	30-38	4-1/2
184/213	355-5	55-5	4-1	30-30	43-28	30-38	5-1/2
215	355-6	55-6	4-1	30-30	43-28	30-38	7
254	355-7	55-7	4-1	30-36	43-16	30-38	8-1/4
256	355-8	55-8	4-2	30-36	43-16	30-23	10
284	355-9	55-9	4-2	30-36	43-16	30-23	9-1/2
286	355-10	55-10	4-2	30-36	43-16	30-23	11
324	355-11	55-11	4-2	30-24	43-33	30-23	10-1/2
326	355-12	55-12	4-2	30-24	43-33	30-23	12

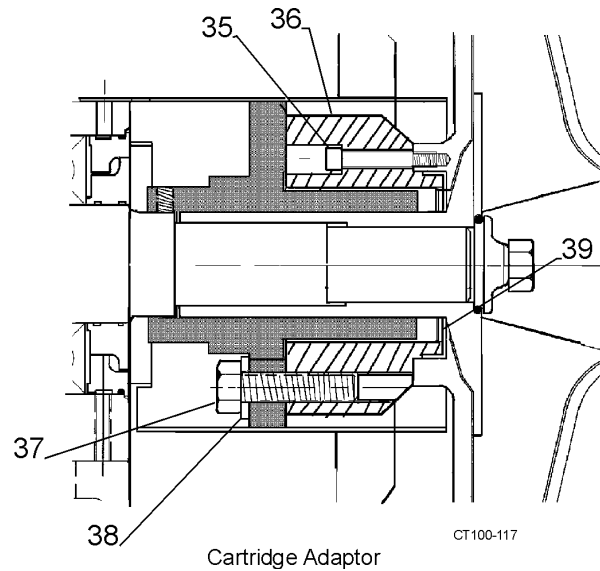

ITEM	PART#	DESCRIPTION	STYLE	MOTOR
1	68-6	BEARING HOUSING 2045	B,C	ALL
	68-7	BEARING HOUSING 2065	B,C	ALL
	68-8	BEARING HOUSING 2075/2085	B,C	ALL
2	62-528X	SHAFT	B,C	ALL
3	23-101	BEARING 6309	B,C	ALL
*4	23-100	BEARING 6209	B,C	ALL
*5	43-139	RETAINING RING	B,C	ALL
6	23-90	SEAL OUTER	B,C	ALL
7	23-89	SEAL INNER	B,C	ALL
*9	N70031	031 O-RING INNER	B,C	ALL
11	30-138X	HHCS 1/2-13 X 2	ALL	ALL
13	30-178	SHSS 1/4-20 X 3/8	B,C	ALL
14	BD0092000	GREASE FITTING	B,C	ALL
15	4-34	STAND	B,C	ALL
16	30-78X	HHCS 1/2-13 X 1	B,C	ALL
*17	N70041	041 O RING OUTER	B,C	ALL
18	70-33	COVER SEAL 2065/2075/2085	B,C	ALL
	70-32	COVER SEAL 2045	B,C	ALL
19	70-31	COVER COUPLING ADAP	B	ALL
23	30-62	HHCS 1/4-20 X 1/2 LG.	B,C	ALL
24	2-247	ADAPTER 56C	B	56C
	2-247	ADAPTER 56C	B	143TC
	2-247	ADAPTER 56C	B	145TC
	2-248	ADAPTER 182TC	B	182TC
	2-248	ADAPTER 182TC	B	184TC

ITEM	PART#	DESCRIPTION	STYLE	MOTOR
	2-248	ADAPTER 182TC	B	213TC
	2-248	ADAPTER 182TC	B	215TC
	2-248	ADAPTER 182TC	B	254TC
	2-248	ADAPTER 182TC	B	256TC
25	43-134	SPACER ADAPTER 213TC	B	213TC
	43-134	SPACER ADAPTER 213TC	B	215TC
	43-135	SPACER ADAPTER 254TC	B	254TC
	43-135	SPACER ADAPTER 254TC	B	256TC
27	11-37	COUPLING HALF.625 W	B,C	56
	11-101	COUPLING HALF.875 5S	B,C	143
	11-101	COUPLING HALF.875 5S	B,C	145
	11-102	COUPLING HALF 1.125 5S	B,C	182
	11-102	COUPLING. HALF 1.125 5S	B,C	184
	11-103	COUPLING. HALF 1.375 6S	B,C	213
	11-103	COUPLING HALF 1.375 6S	B,C	215
	11-41	COUPLING HALF 1.625 7S	B,C	254
	11-41	COUPLING. HALF 1.625 7S	B,C	256
*28	11-29	COUPLING SLEEVE 4J	B,C	56
	11-30	COUPLING SLEEVE 5JE	B,C	143/184
	11-31	COUPLING SLEEVE 6JE	B,C	213/215
	11-32	COUPLING SLEEVE 7JE	B,C	254/256
29	11-95	COUPLING HALF 1.0 4J	B,C	56
	11-94	COUPLING HALF 1.0 5S	B,C	143/184
	11-96	COUPLING HALF 1.0 6S	B,C	213/215
	11-97	COUPLING HALF 1.0 7S	B,C	254/256
30	30-35	HHCS 3/8-16 X 1	B	56/145
	30-78X	HHCS 1/2-13 X 1	B	182/184
	30-127X	HHCS 1/2-13 X1-3/4	B	213/215
	30-87X	HHCS 1/2-13 X 2-1/2	B	254/256
32	30-103	HHCS 1/2-13 X 1-1/2	B,C	ALL
33	43-31	WASHER 1/2	B,C	ALL
34	43-16	LOCK WASHER 1/2	B,C	ALL
35	30-222X	SHCS 1/4-20 X 1-1/2	B,C	ALL
36	23-91X	ADAPTER, CART. SEAL	B,C	ALL
37	30-127X	HHCS 1/2-13 X 1-3/4	B,C	ALL
38	43-31X	FLAT WASHER 1/2	B,C	ALL
*39	9-37	L-GASKET FKM	B,C	ALL
	9-37E	L-GASKET EPDM	B,C	ALL
	9-37K	L-CASKET FFKM	B,C	ALL

*Recommended spare parts.

Pedestal Mounted Pumps Large Bore

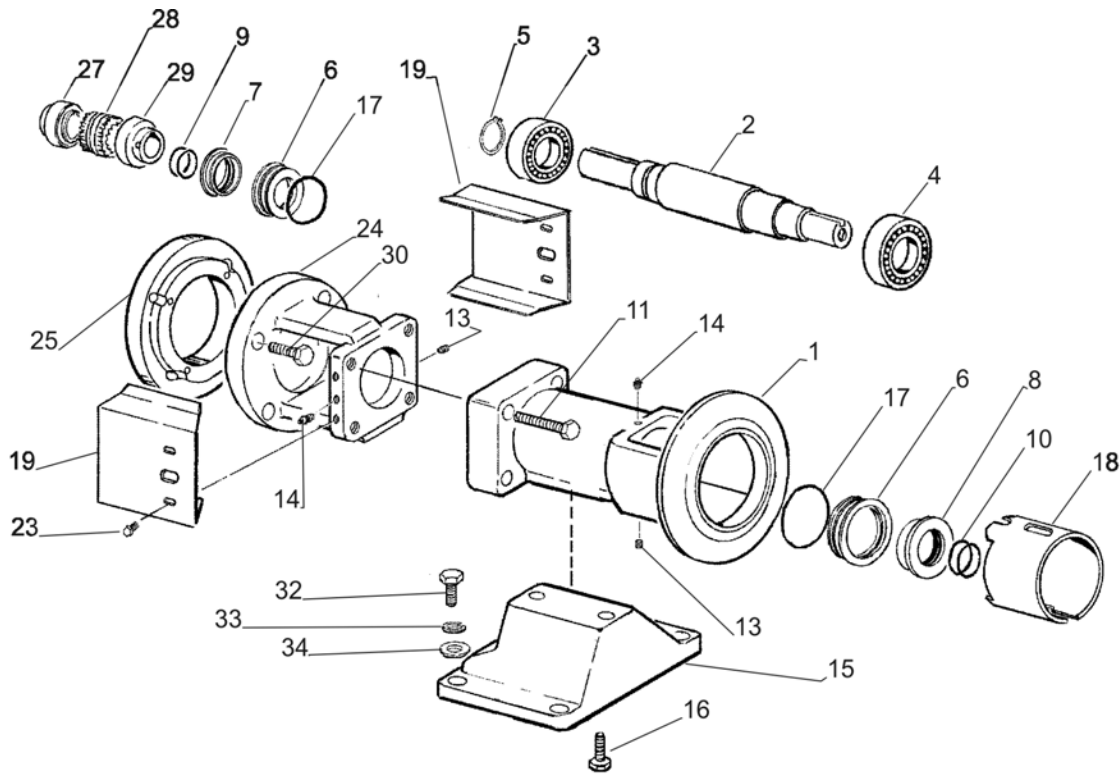

Style "B" Large Bore

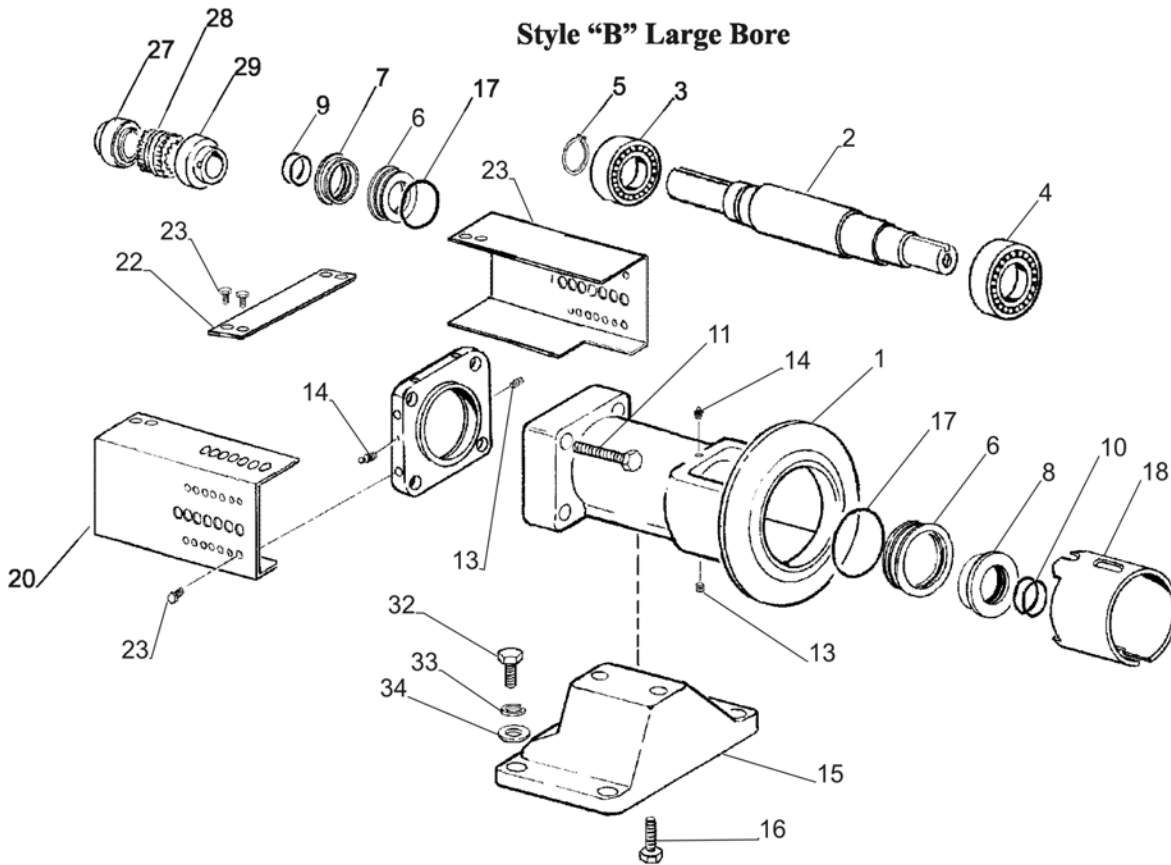

Style "C" Large Bore

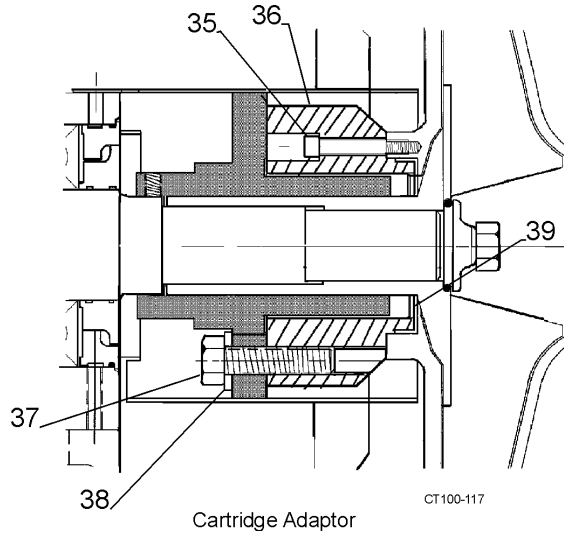

ITEM	PART#	DESCRIPTION	STYLE	MOTOR
1	68-9	BEARING HOUSING 2065	B,C	ALL
	68-10	BEARING HOUSING 2075/2085	B,C	ALL
	68-11	BEARING HOUSING 2105	B,C	ALL
2	62-539X	SHAFT	B,C	ALL
*3	23-98	BEARING 6309	B,C	ALL
*4	23-99	BEARING 6209	B,C	ALL
*5	43-138	RETAINING RING	B,C	ALL
6	23-95	SEAL OUTER	B,C	ALL
7	23-94	SEAL INNER MOTOR END	B,C	ALL
8	23-93	SEAL INNER IMP. END	B,C	ALL
*9	N70035	035 O-RING INNER	B,C	ALL
*10	N70033	033 O-RING INNER IMP.	B,C	ALL
11	30-221X	HHCS 1/2-13 X 3-1/4	ALL	ALL
13	30-178	SHSS 1/4-20 X 3/8	B,C	ALL
14	BD0092000	GREASE FITTING	B,C	ALL
15	4-35	STAND	B,C	ALL
16	30-21	HHCS 1/2-13 X 1-1/4	B,C	ALL
*17	N70045	045 O-RING OUTER	B,C	ALL
18	70-37	SEAL GUARD 2105	B,C	ALL
	70-33	SEAL GUARD 2065/2075/2085	B,C	ALL
19	70-34	COVER COUPLING ADAP.	B	ALL
20	70-35	COVER COUPLING L.H.	C	ALL
21	70-36	COVER COUPLING R. H.	C	ALL
22	2-252	BRACE,COVER COUPLING	C	ALL
23	30-62	HHCS 1/4-20 X 1/2 LG.	B,C	ALL
24	2-249	ADAPTER 213TC	B	213TC
	2-249	ADAPTER 213TC	B	215TC
	2-249	ADAPTER 213TC	B	254TC
	2-249	ADAPTER 213TC	B	256TC
	2-250	ADAPTER 284TC	B	284TC

ITEM	PART#	DESCRIPTION	STYLE	MOTOR
	2-250	ADAPTER 284TC	B	286TC
	2-250	ADAPTER 284TC	B	324TC
	2-250	ADAPTER 284TC	B	326TC
	2-250	ADAPTER 284TC	B	364TC
	2-250	ADAPTER 284TC	B	365TC
25	43-134	SPACER ADAPTER 213TC	B	254TC
	43-134	SPACER ADAPTER 213TC	B	256TC
	43-136	SPACER ADAPTER 324TC	B	324TC
	43-136	SPACER ADAPTER 324TC	B	326TC
25	43-137	SPACER ADAPTER 364TC	B,C	364TC
	43-137	SPACER ADAPTER 364TC	B,C	365TC
26	23-97	END CAP HOUSING LB	C	ALL
27	11-103	COUP. HALF 1.375 6S	B,C	213
	11-103	COUP. HALF 1.375 5S	B,C	215
	11-41	COUP. HALF.1.625 7S	B,C	254
	11-41	COUP HALF 1.625 7S	B,C	256
	11-105	COUP. HALF 1.875 7S	B,C	284
	11-105	COUP. HALF 1.875 7S	B,C	286
	11-106	COUP. HALF 2.125 8S	B,C	324
	11-106	COUP. HALF 2.125 8S	B,C	326
	11-107	COUP. HALF 2.375 8S	B,C	364
	11-107	COUP. HALF 2.375 8S	B,C	365
*28	11-31	COUP. SLEEVE 6JE	B,C	213/215
	11-32	COUP. SLEEVE 7JE	B,C	254/286
	11-33	COUP. SLEEVE 8JE	B,C	324/326
	11-108	COUP. SLEEVE 8H	B,C	364/365
29	11-98	COUP. HALF1.250 6S	B,C	213/215
	11-99	COUP. HALF1.250 7S	B,C	254/289
	11-100	COUP. HALF1.250 8S	B,C	324/365
30	30-21	HHCS 1/2-13 X 1-1/4	B	213/215
	30-21	HHCS 1/2-13 X 1-1/4	B	324/365
31	30-227X	SHCS 5/8-11 X 1	B	324/326
	30-228X	SHCS 5/8-11 X 1-3/4	B	364/365
32	30-103X	HHCS 1/2-13 X 1-1/2	B,C	ALL
33	43-31	WASHER 1/2	B,C	ALL
34	43-16	LOCK WASHER 1/2	B,C	ALL
35	30-222X	SHCS 1/4-20 X 1-1/2	B,C	ALL
36	23-91X	ADAPTER, CART. SEAL	B,C	ALL
37	30-127X	HHCS 1/2-13 X 1-3/4	B,C	ALL
38	43-31X	FLAT WASHER 1/2	B,C	ALL
*39	9-37	L-GASKET FKM	B,C	ALL
	9-37E	L-GASKET EPDM	B,C	ALL
	9-37K	L-CASKET FFKM	B,C	ALL

*Recommended spare parts.

Metric System Parts

METRIC IMPELLERS	
PART #	MODEL
5-224X	2045
5-230X	2065
5-242X	2085
5-234X	2065HV
5-238X	2075/2085LV
5-226X	2065LV
5-246X	2105

USING METRIC MOTORS REQUIRES:
*Metric Key
Metric Impeller
*Metric Adapter
*Metric Fasteners
**Metric Seal Components
*Metric Impeller Bolt

METRIC MOTORS
FRAME SIZE
200
180
160
132
112
100
90

* For part numbers not listed contact your distributor.

**43mm impeller shaft seals are listed on page 50.

*43 MM. (SHAFT DIAMETER) IMPELLERS				
MODEL	PART#	PEDESTAL	TYPE	DIAMETER
2045	5-170XA	SM. BORE	INDUSTRIAL	4.500
2045	5-170X	SM. BORE	SANITARY	4.500
2065LV	5-172XA	SM. BORE	INDUSTRIAL	6.500
2065LV	5-172X	SM. BORE	SANITARY	6.500
2065LV	5-174XA	LG. BORE	INDUSTRIAL	6.500
2065	5-176XA	SM. BORE	INDUSTRIAL	6.500
2065	5-176X	SM. BORE	SANITARY	6.500
2065	5-178XA	LG. BORE	INDUSTRIAL	6.500
2065	5-178X	LG. BORE	SANITARY	6.500
2065HV	5-180XA	SM. BORE	INDUSTRIAL	6.500
2065HV	5-180X	SM. BORE	SANITARY	6.500
2065HV	5-182XA	LG. BORE	INDUSTRIAL	6.500
2065HV	5-182X	SM. BORE	SANITARY	6.500
2075/2085LV	5-184XA	SM. BORE	INDUSTRIAL	8.500
2085LV	5-184X	SM. BORE	SANITARY.	8.500
2085LV	5-186XA	LG. BORE	INDUSTRIAL	8.500
2085LV	5-186X	LG. BORE	SANITARY	8.500
2085	5-188XA	SM. BORE	INDUSTRIAL	8.500
2085	5-188X	SM. BORE	SANITARY	8.500
2085	5-190XA	LG. BORE	INDUSTRIAL	8.500
2085	5-190X	LG. BORE	SANITARY	8.500
2105	5-192XA	SM. BORE	INDUSTRIAL	10.500
2105	5-192X	SM. BORE	SANITARY	10.500
2105	5-194XA	LG. BORE	INDUSTRIAL	10.500

*43mm Shafts measure 1.693 outside shaft diameter.

Troubleshooting

PROBLEM	POSSIBLE CAUSE	SUGGESTED ACTION
Not Enough Liquid Delivered	Pump not primed.	Prime pump. Install a priming system if possible.
	Suction or discharge plugged or closed.	Open suction. If plugged <u>shutdown pump</u> and remove blockage.
	Air leak in supply or at seal area.	Check system for air leaks and repair as necessary. Replace seals if required.
	Wrong direction of rotation.	Adjust motor electrical wiring to correct rotation.
	Discharge head too high.	Lower discharge head until pump can move material without turning to freely, causing overload.
	Suction lift too high.	Lower pump in system until the pump is easily supplied with material.
	Speed too slow (low voltage, wrong frequency, wrong motor).	Adjust voltage and frequency. Change motor if necessary.
	Excessive air in material.	Adjust system to remove excess air from material before it reaches the pump.
	Insufficient NPSH (Net Positive Suction Head) available.	Adjust system to provide correct NPSH.
Impeller diameter too small for duty.	Contact your Waukesha Cherry-Burrell customer service representative for sizing information. WCB Customer Service: 1-800-252-5200 or 262-728-1900	
Not Enough Pressure	Air leak in supply or at seal area.	Check system for air leaks and repair as necessary. Replace seals if required.
	Wrong direction of rotation.	Adjust motor electrical wiring to correct rotation.
	Speed too slow (low voltage, wrong frequency, wrong motor).	Adjust voltage and frequency. Change motor if necessary.
	Excessive air in material.	Adjust system to remove excess air from material before it reaches the pump.
	Impeller diameter too small for duty.	Contact your Waukesha Cherry-Burrell customer service representative for sizing information. WCB Customer Service: 1-800-252-5200 or 262-728-1900

PROBLEM	POSSIBLE CAUSE	SUGGESTED ACTION
Motor Overload	Faulty electrical connections.	Check wiring and repair/replace as necessary.
	Unrestricted discharge resulting in too high a flow rate.	Add discharge restriction to lower flow rate.
	Impeller interference.	Disassemble pump and inspect for damage. Remove interference if still present. Replace worn/damaged parts.
	Seal binding.	Disassemble pump and inspect for damage. Check for material crystallization on seals.
	Discharge head too low allowing pump to deliver too much liquid.	Raise discharge head until pump achieves proper resistance to flow.
	Liquid heavier or more viscous than rating.	Contact your Waukesha Cherry-Burrell customer service representative for sizing information. WCB Customer Service: 1-800-252-5200 or 262-728-1900
	Overload heaters too small for motor.	Inspect and replace as necessary.
	Electrical supply, voltage, frequency, incorrect.	Adjust voltage and frequency. Change motor if necessary.
	Impeller diameter too large for duty.	Contact your Waukesha Cherry-Burrell customer service representative for sizing information. WCB Customer Service: 1-800-252-5200 or 262-728-1900
	Defective motor.	Replace motor.
Vibration/Noise	Pump not level.	Make sure all legs are touching the floor. Level pump.
	Piping not supported.	Support all piping as described in the installation section.
	Starved suction/Supply line blocked.	<u>Shutdown pump</u> and remove blockage.
	Foreign material in pump.	Disassemble pump, remove all foreign material and inspect for damage. Replace worn/damaged parts.
	Starved suction/Insufficient NPSH (Net Positive Suction Head) available.	Adjust system to provide correct NPSH.
	Impeller hub/impeller shaft worn.	Disassemble pump and inspect for damage. Replace worn parts.
	Impeller shaft loose or bent.	Disassemble pump and inspect for damage.
	Impeller out of balance.	Disassemble pump and inspect for damage. Replace impeller.

PROBLEM	POSSIBLE CAUSE	SUGGESTED ACTION
	Motor bearings worn.	Disassemble motor and inspect for damage. Replace worn parts.
	Starved suction/supply line too long.	Shorten system supply line.
	Starved suction/supply line too small.	Install larger supply lines.
	Excessive air in material.	Adjust system to remove excess air from material before it reaches the pump.
Rapid Seal Wear	Incorrect impeller shaft location; excessive spring loading.	Adjust pump alignment to motor and piping.
	Water Hammer.	Adjust system to reduce air in system and sudden starts or stops in flow.
	Impeller shaft loose or bent.	Disassemble pump and inspect for damage. Replace worn/damaged parts.
	Abrasive product.	Contact your Waukesha Cherry-Burrell customer service representative for sizing information. WCB Customer Service: 1-800-252-5200 or 262-728-1900
	Prolonged “dry” running.	Adjust process to insure pump has a continual fresh supply of product during operation.
	Abrasive solids (unfiltered) in flush water supplied to seal.	Use only filtered water in seal flush system.
Seal Leaks	Gasket damaged or worn.	Disassemble pump and inspect for damage.
	Seal not installed correctly.	Disassemble pump and inspect seal for damage (replace if necessary). Install seal correctly and assemble pump.
	Carbon seal worn or damaged.	Disassemble pump and inspect seal for damage (replace if necessary).
	Inlet/Outlet connection loose or no gasket.	Inspect Inlet/outlet connection for gasket and tighten connection.
	Casing clamp loose.	Tighten clamp.

SPX Process Equipment

611 Sugar Creek Road • Delavan, WI 53115 USA

Tel: (800) 252-5200 or (262) 728-1900 • Fax: (800) 252-5012 or (262) 728-4904

E-mail: info@processequipment.spx.com • Web site: www.spxprocessequipment.com

Issued: December 2001 • Revised: April 2005

95-03009